

Care instructions ESTETICA E50



Always be on the safe side.



KaVo. Dental Excellence.

Distributed by:
KaVo Dental GmbH
Bismarckring 39
D-88400 Biberach
Tel. +49 7351 56-0
Fax +49 7351 56-1488

Manufacturer:
Kaltenbach & Voigt GmbH
Bismarckring 39
D-88400 Biberach
www.kavo.com



Table of contents

1	User instructions	2
1.1	User guide	2
1.1.1	Abbreviations	2
1.1.2	Symbols	2
1.1.3	Target group	2
2	Setup methods according to DIN EN ISO 17664	3
2.1	References	3
2.2	General instructions for the reprocessing of KaVo treatment units	3
2.2.1	Overview ESTETICA E50 reprocessing	5
2.3	Reprocessing of the surfaces of treatment unit / upholstery	5
2.4	Preparation of the dentist unit	7
2.4.1	Reprocessing of handle and holder pads	7
2.4.2	Reprocessing of the instrument holder of the TM table	9
2.4.3	Reprocessing of the three- and multi-function syringe	9
2.4.4	Preparation of the instrument hoses	13
2.4.5	Servicing the turbine return air filter	13
2.4.6	Reprocessing of the kit for physiological saline solution	14
2.5	Reprocessing of the assistant unit	15
2.5.1	Preparing the connector for the suction hose	15
2.5.2	Reprocessing of sieve inserts and suction hoses	15
2.6	Preparation of the patient unit	16
2.6.1	Preparation of the tumbler	16
2.6.2	Preparation of the tumbler holder and filler	16
2.6.3	Preparation of the spittoon	18
2.7	Automatic hygiene function of the water-conducting system	18
2.7.1	Rinsing programme	19
2.7.2	Intensive disinfection	22
2.8	Reprocessing and automatic hygiene functions of the suction system	25
2.8.1	Reprocessing of the suction system including suction hoses	25
2.8.2	HYDROclean function	25
2.9	Preparation of the amalgam separator	26
3	Replenish and check the disinfectant	27
3.1	Replenish oxygenal	27
3.1.1	Refilling oxygenal when using the water bottle	28
3.2	Checking the oxygenal concentration	32

1 User instructions

1.1 User guide

Requirement

Read these instructions prior to first use to avoid misuse and prevent damage.



Note

Comply with the Instructions for Use of the ESTETICA E50 treatment unit!

1.1.1 Abbreviations

Abbreviation	Explanation
GA	Instructions for use
PA	Care instructions
REC	Assembly instructions
TA	Technician's instructions
STK	Safety checks
IEC	International Electrotechnical Commission
RA	Repair instructions
EMC	Electro magnetic compatability
scaler	Concrement remover
IR	Infrared
IrDA	Infrared Data Association

1.1.2 Symbols

	Refer to Safety/Warning symbol chapter
	Important information for users and technicians
	Action request
	CE mark according to EC Directive 93/42 for medical devices
	Thermoisinfectable at up to 95 °C (203 °F)
	Sterilisable in steam at up to 135 °C (275 °F)

1.1.3 Target group

This document is for dentists and office personnel.

2 Setup methods according to DIN EN ISO 17664

2.1 References

The reprocessing consists of the following basic steps:

- Cleaning and disinfection (manually or automatically)
- Sterilisation



Note

Comply with national hygiene requirements, e.g. RKI guidelines.

	<p>⚠ CAUTION</p>
	<p>Risk of injury during cleaning of the treatment unit. Lack of instructions to the cleaning staff and lack of preparation of the treatment unit can lead to the cleaning personnel sustaining injuries.</p> <ul style="list-style-type: none"> ▶ Only trained professionals and instructed cleaning personnel may be present in the treatment rooms. ▶ Position the chair for cleaning and turn the device off.

	<p>⚠ CAUTION</p>
	<p>Product damage due to improper disinfection. Malfunctions.</p> <ul style="list-style-type: none"> ▶ Use disinfectant in accordance with the instructions of the manufacturer. ▶ No spray disinfection, perform wipe disinfection only. ▶ Do not immerse product or product parts in liquids.

	<p>⚠ CAUTION</p>
	<p>Improper disinfection may lead to health hazards and material damage. Infection hazard to users and patients. Damage to the sterile product.</p> <ul style="list-style-type: none"> ▶ No hot air sterilisation, no chemical cold sterilisation, do not sterilise with ethylene oxide.





Note

The preparation methods for the instruments and motors are found in the separate instructions for use that accompany the instrument and motor packages.

2.2 General instructions for the reprocessing of KaVo treatment units

Please comply with the general reprocessing instructions at all times. Detailed product-specific reprocessing instructions are provided subsequently.

At the site of use	▶ Remove surface contamination using a disposable cloth/paper towel.
Storage and transport	KaVo recommends reprocessing as soon as possible after use.

Cleaning preparations	<ul style="list-style-type: none"> ▶ Comply with product-specific reprocessing instructions.
Manual cleaning	<p>Fixtures:</p> <ul style="list-style-type: none"> ▪ Brush or cloth ▪ Tap water 30 °C ± 5 °C <ul style="list-style-type: none"> ▶ Rinse surface contamination off the product under running water.
Automatic cleaning	<p>KaVo recommends thermodisinfection at up to 95 °C according to ISO 15883-1, e.g. Miele G 7781 / G 7881.</p>  <ul style="list-style-type: none"> ▶ For program settings as well as cleansers and disinfectants to be used, please refer to the Instructions for Use of the thermodisinfector. ▶ Do not clean instruments and device components in the ultrasound bath.
Manual disinfection	<ul style="list-style-type: none"> ▶ Perform wipe disinfection only, the use of spray disinfection and disinfection baths is not feasible. ▶ Wipe all outer surfaces with a soft cloth and an approved disinfectant. <p>Approved disinfectants:</p> <ul style="list-style-type: none"> ▪ Microcide liquid (Schülke & Mayr) ▪ FD 322 (Dürr) ▪ Incidin Liquid (Ecolab) ▪ CaviCide (Metrex) <ul style="list-style-type: none"> ▶ Use disinfectants according to the manufacturer's Instructions for Use. ▶ Please note the disinfectant safety data sheet.
Automatic disinfection	<p>KaVo recommends thermodisinfection at up to 95 °C according to ISO 15883-1, e.g. Miele G 7781 / G 7881.</p>  <ul style="list-style-type: none"> ▶ For program settings as well as cleansers and disinfectants to be used, please refer to the Instructions for Use of the thermodisinfector. ▶ Do not disinfect instruments and device components in the ultrasound bath.
Manual drying	<ul style="list-style-type: none"> ▶ Ensure dry, clean and uncontaminated compressed air according to ISO 7494-2. ▶ Blow off the outside and inside with compressed air until water drops are no longer visible.
Automatic drying	<p>Automatic drying usually is part of the cleaning/disinfection cycle of the thermodisinfector and should not be carried out above 95 °C.</p>
Service	<ul style="list-style-type: none"> ▶ Discard damaged products.
Control and function test	<ul style="list-style-type: none"> ▶ Perform a visual inspection checking for damage and wear and tear. ▶ Test products for function regularly.
Packaging	<ul style="list-style-type: none"> ▶ Use standardised packaging material. Sealing should not be under tension.

<p>Sterilisation</p> <div style="border: 1px solid black; padding: 5px; width: fit-content; margin: 10px auto;"> <p style="text-align: center;">135 °C</p>  </div>	<p>All sterilisable products are temperature resistant up to max. 138 °C. KaVo recommends sterilisation in a steam steriliser (autoclave) according to EN 13060 / ISO 17665-1, e.g. STERlclave B 2200 / 2200 P (KaVo) or Citomat K-Series (Getinge).</p> <ul style="list-style-type: none"> ▶ Sterilise with a triple fractionated vacuum (B class steriliser); hold for 4 minutes; 134°C ± 1 °C; overpressure: 2.13 bar.
<p>Storage</p>	<ul style="list-style-type: none"> ▶ Rehabilitated products should be stored protected from dust with minimum exposure to germs in a dry, dark and cool space. ▶ Comply with the expiration date of the sterilised item.

2.2.1 Overview ESTETICA E50 reprocessing

Reprocessing items/medical devices	Cleaning		Disinfection		Sterilisation
	manual	automatic	manual	automatic	automatic
Surfaces					
Device	X		X		
Cushion	X		X		
Gripping sleeve, white	X	X	X	X	
Gripping sleeve, grey	X	X	X	X	X
Lamp and reflector	X		X		
Dentist element					
Syringe sleeve for 3F and MF syringes	X		X		X
Cannula for 3F and MF syringes	X		X		X
Holder pad	X	X	X	X	
Instrument holder	X		X		
Assistant element					
Connection parts of the suction hose	X	X	X	X	
Patient unit					
Tumbler support	X		X		
Tumbler filler	X	X	X	X	
Glass spittoon bowl	X		X		
Porcelain spittoon bowl	X	X	X	X	

2.3 Reprocessing of the surfaces of treatment unit / upholstery

Position the chair for cleaning

- ▶ Adjust the backrest to vertical position and move the chair upward.

See also: Instructions for UseESTETICA E50

Turn device off

- ▶ Switch main device switch off.

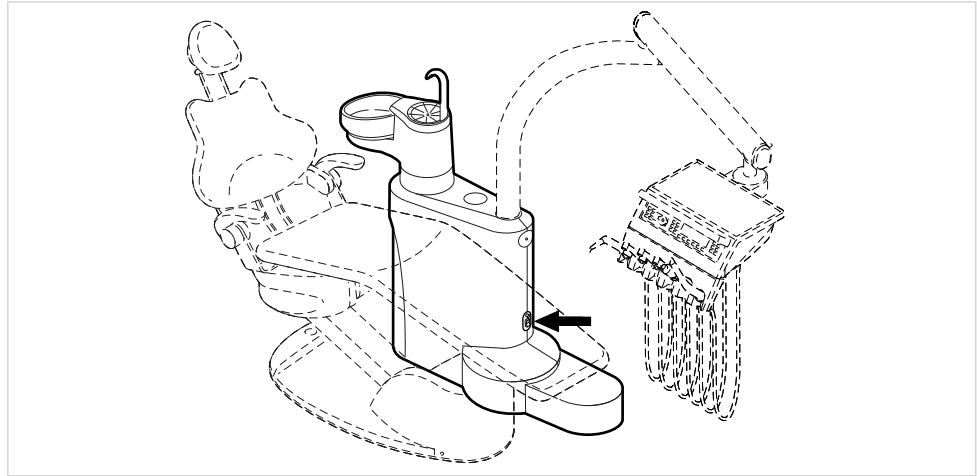

Cleaning and disinfecting the surfaces of treatment unit / upholstery



⚠ CAUTION

Non-colour-fast textiles.

Non-colour-fast textiles can cause permanent discoloration.

- ▶ Remove discolourations with water immediately.

Approved disinfectants:

- Microcide liquid (Schülke & Mayr)
- FD 322 (Dürr)
- Incidin Liquid (Ecolab)
- CaviCide (Metrex)

- ▶ Clean the surfaces and upholstery with a soft cloth and water, and wipe-disinfect them with an approved surface disinfectant.



⚠ CAUTION

Damage caused by spray disinfection.

Disinfectant gets into cracks and loosens the paint.

- ▶ No spray disinfection.
- ▶ Only disinfect by wiping.

Cleaning and disinfection of the foot control

	⚠ CAUTION
	<p>Damage caused by inappropriate use of water. Damage to the foot control.</p> <ul style="list-style-type: none">▶ For cleaning, the foot control must not be immersed in water or placed under running water.▶ When wiping it off with a moist cloth, do not touch the contacts of the charge socket.▶ Only wipe off. Do not spray.



2.4 Preparation of the dentist unit

2.4.1 Reprocessing of handle and holder pads



Note

The handle of the TM table cannot be detached.

Cleaning and disinfection of the handle of the TM table

- ▶ Clean the handle with a soft cloth and water, and wipe-disinfect it with an approved surface disinfectant.

Cleaning and disinfection of the handle of the S table and holder pads

- ▶ Press the push button and pull off the handle.

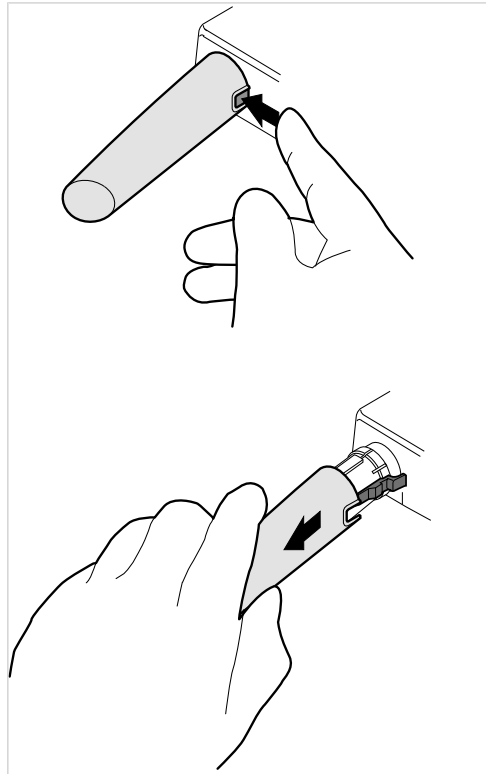

- ▶ Clean the handle under flowing water.
- ▶ Disinfect the white and grey handle by wiping or thermodisinfection (minor discolouration may occur).
- ▶ Thermodisinfect the holder pad.



Sterilisation of the handle of the S table and holder pads

	⚠ CAUTION
	Damage caused by sterilisation. <ul style="list-style-type: none">▶ Do not sterilise the white standard handle.▶ Do not sterilise holder pads.



The grey handle (**Mat. no. 1.002.4489**) can be sterilised (see symbol on the handle).

2.4.2 Reprocessing of the instrument holder of the TM table

Cleaning and disinfection of the instrument holder

	⚠ CAUTION
	Damage caused by thermodisinfection. <ul style="list-style-type: none">▶ Do not thermodisinfest the instrument holder.

- ▶ Pull the snap-in buttons outward evenly and carefully remove the instrument holder.

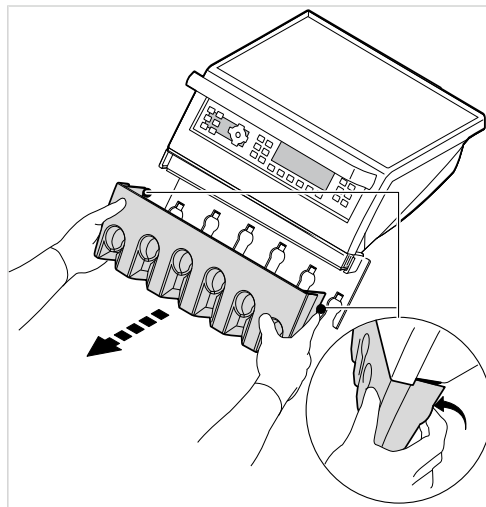

- ▶ Clean the instrument holder under running water.
- ▶ Wipe-disinfect the instrument holder.

Sterilize the instrument holder

	⚠ CAUTION
	Damage caused by sterilisation. <ul style="list-style-type: none">▶ Do not sterilise the instrument holder.

2.4.3 Reprocessing of the three- and multi-function syringe



Note

Wet the O-ring with silicone grease (**Mat. no. 1.000.6403**) or KaVo Rota Spray 2 (**Mat. no. 0.411.7510**) after sterilisation. After replacing the cannula, the air channel must be blown out before the start of treatment to ensure that the air exiting during treatment is dry.

Cleaning of the three- and multi-function syringe

Machine cleaning

Not applicable.

	⚠ CAUTION
	<p>Damage caused by improper cleaning/disinfection.</p> <ul style="list-style-type: none"> ▶ Do not wash the gripping sleeve and the cannula in the thermodisinfector. ▶ Do not sterilise the gripping sleeve and the cannula in the hot-air steriliser. ▶ Do not place the gripping sleeve and the cannula in a disinfectant or ultrasonic bath.

Manual cleaning



Note

Combine manual cleaning with disinfection.

Cleaning the interior

- ▶ Leave the gripping sleeve and cannula on the instrument, and activate the air and water for 60 seconds.

External cleaning

	⚠ CAUTION
	<p>Danger of injury if the valve body is hot (heating elements, high-pressure lamp). Risk of burn injury.</p> <ul style="list-style-type: none"> ▶ Switch main device switch off. ▶ Allow the syringe to cool down after extended use.

Accessories required:

- Tap water 30°C ± 5°C
 - Brush, e.g. medium-hard toothbrush
-
- ▶ Disassemble the gripping sleeve and cannula.
 - ▶ Detach the key part from the gripping sleeve.
 - ▶ Clean the key part, gripping sleeve and cannula by brushing them under running water (at least tap water quality).
 - ▶ Immediately remove contamination from materials used in the dental practice (impression material, caustic chemicals).
 - ▶ Carefully wipe off contamination from the cannula tip with a soft Q-tip or soft cloth and alcohol.

	⚠ CAUTION
	<p>Damage caused by using a nozzle needle that is too long. Damage to the internal hoses of the cannula.</p> <ul style="list-style-type: none"> ▶ Use a short nozzle needle (Mat. no. 0.410.0921) to clean the media exit holes.

- ▶ Carefully remove contamination from the media exit holes using the short nozzle cleaning needle.

Disinfection of the three- and multi-function syringe

Manual disinfection

External disinfection

- ▶ Wipe-disinfect the surfaces with a soft cloth.

Automated disinfection

Not applicable.

	⚠ CAUTION
	<p>Damage caused by improper cleaning/disinfection.</p> <ul style="list-style-type: none"> ▶ Do not wash the gripping sleeve and the cannula in the thermodisinfector. ▶ Do not sterilise the gripping sleeve and the cannula in the hot-air steriliser. ▶ Do not place the gripping sleeve and the cannula in a disinfectant or ultrasonic bath.

Drying of the three- and multi-function syringe

Manual drying

- ▶ Blow off the outside and inside the compressed air until no water drops are visible.

Machine drying

Not applicable.

Taking care of the three- and multi-function syringe

Requirement

The multi-function syringe has been rehabilitated.

- ▶ Apply KaVo silicone grease (**Mat. no. 1.000.6403**) or KaVo Rota Spray 2 (**Mat. no. 0.411.7510**) to the O-rings of the joint between the gripping sleeve and cannula. Use cotton buds for this purpose.

Sterilisation of the three- and multi-function syringe



Note

The grip sleeve and cannula can be sterilised.

- ▶ Remove the cannula with a slight amount of rotation while holding the tip on the grip sleeve.

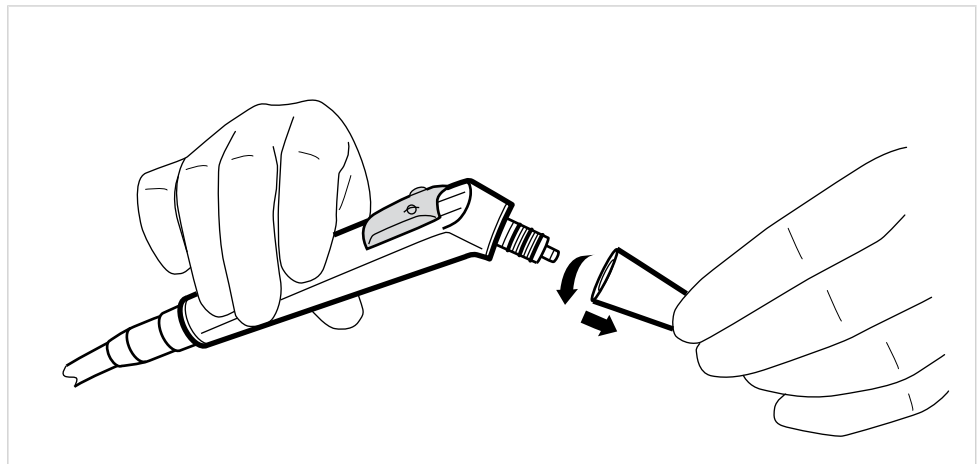

- ▶ Pull the gripping sleeve off the valve body.

Sterilization in a steam sterilizer in compliance with DIN EN 13060



The medical device is resistant to temperatures of up to 138 °C.

KaVo recommends, e.g.:

- STERiclave B 2200/ 2200P made by KaVo
- Citomat/ K-series made by Getinge



- ▶ Weld the cannula and grip sleeve in sterile goods packaging.
- ▶ Sterilise with a triple fractionated vacuum (B class steriliser); hold for 4 minutes; 134°C ± 1 °C; overpressure: 2.13 bar.



⚠ CAUTION

Damage caused by over-heating.
Damage to the gripping sleeve.

- ▶ Immediately remove parts from the steriliser after the sterilisation cycle.

Storage

- ▶ Prepared products should be stored protected from dust with minimum exposure to germs in a dry, dark and cool room.

2.4.4 Preparation of the instrument hoses

Cleaning and disinfection of instrument hoses

- ▶ Clean the hoses and couplings with a cloth and water.

	⚠ CAUTION
	Damage caused by spray disinfection. <ul style="list-style-type: none">▶ Do not subject instrument hoses to spray disinfection.▶ Subject instrument hoses to wipe disinfection.

2.4.5 Servicing the turbine return air filter

Cleaning the turbine return air filter



Note

The liquid collector must be checked weekly.

- ▶ If liquid is in the filter , drain the liquid and replace the O-rings of the multiflex couplings.

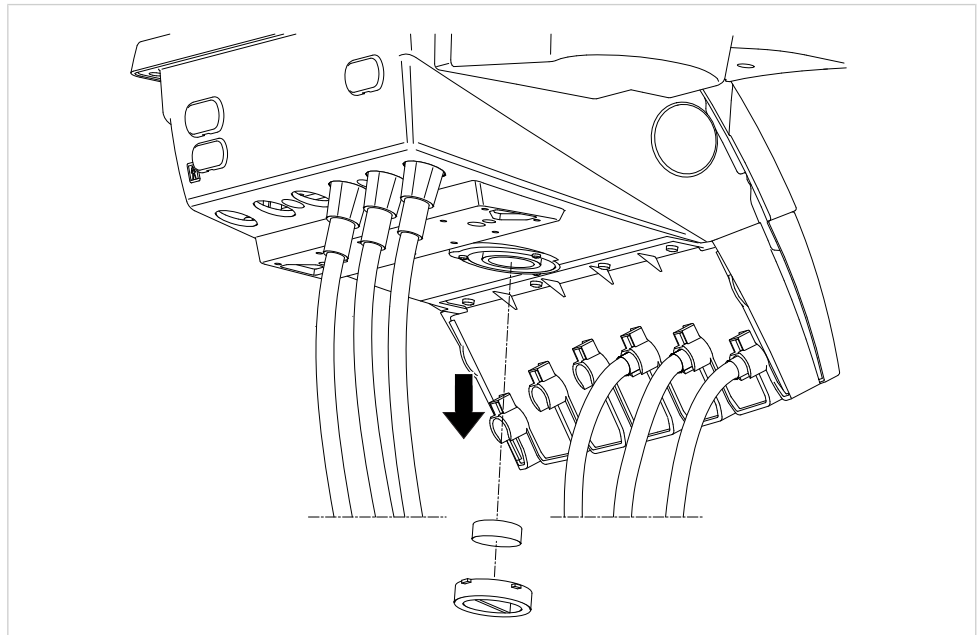

- ▶ If needed, exchange the return air filter (**Mat. no. 0.200.3098**) and clean the filter seat.



Note

The return air filter is in the same position in the dentist unit variant with S table.

2.4.6 Reprocessing of the kit for physiological saline solution

The kit for physiological saline solution is optional.



Note

The silicone hoses of the kit must be sterilised after each patient.

Cleaning the kit for physiological saline solution

When using saline solution, all lines conducting the solution must be rinsed directly after treating the patient.

- ▶ Pull out the suction hose from the NaCl bag.
- ▶ Immerse the pump hose needle in a container with distilled water (min. 150 ml).
- ▶ Activate the pump, and pump distilled water completely through it.

Sterilisation kit for physiological saline solution



Note

The following parts can be subjected to sterilisation:
 – Silicone hoses for saline solution and their connecting nipples



CAUTION

Damage caused by sterilisation.

- ▶ Do not sterilise instrument hoses and hose clips for saline hose.

Requirement

The hoses for the physiological saline solution are rinsed.



- ▶ Seal the motor holder, handpieces, and contra-angle handpieces (and instruments if applicable) in a sterilisation bag and sterilise them.

2.5 Reprocessing of the assistant unit

2.5.1 Preparing the connector for the suction hose

- ▶ Remove connectors ① and ② from the suction hoses.

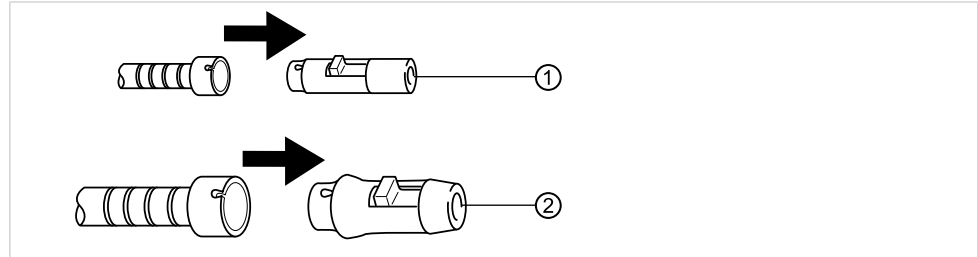

Cleaning and disinfection of the suction hose connector



- ▶ Thermodisinfect the disassembled parts for at least 10 minutes at 93 °C (total cycle: approximately 20 minutes)

Sterilising the suction hose connector

	⚠ CAUTION
	<p>Damage caused by sterilisation.</p> <ul style="list-style-type: none"> ▶ Do not sterilise the suction hose connector.



Note

Sterilise the suction cannulas according to the manufacturer's instructions.

2.5.2 Reprocessing of sieve inserts and suction hoses



Note

Check the sieve inserts daily and after each surgery. The sieves must be replaced at the latest when the suction decreases (**Mat. no. 0.763.3423**). Cleaning is not recommended for hygienic reasons.

- ▶ Remove the suction hoses from the holder.

The suction motor starts automatically when the suction tubes are removed from the holder.

- ▶ Hold the napkin under the sieve seat, and pull the sieves out of the housing.

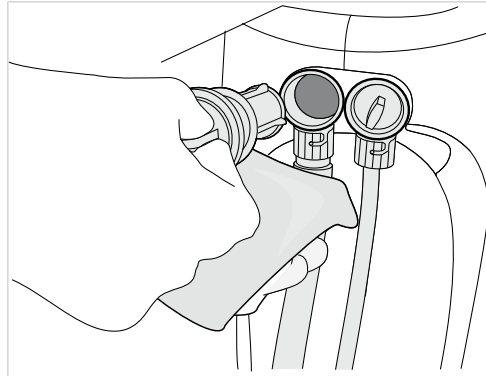

- ▶ If needed, insert a new sieve insert (**Mat. no. 0.763.3423**) into the seat.
- ▶ Wipe the suction tubes with disinfectant.

2.6 Preparation of the patient unit

2.6.1 Preparation of the tumbler

- ▶ Reprocess as specified by the manufacturer.

2.6.2 Preparation of the tumbler holder and filler

Cleaning and disinfection of the tumbler holder and filler



Note

When assembling, make sure that the O-ring is present on the tumbler filler.



Note

Inspect the O-ring (**Mat. no. 0.200.6128**) for damage and exchange if necessary to prevent water or oxidation damage.



- ▶ Remove tumbler holder ① (**Mat. no. 0.764.8541**) by pulling upwards.
- ▶ Take off the tumbler holder ③ (**Mat. no. 0.764.6153**).
- ▶ Clean the tumbler holder and tumbler filler under running water.
- ▶ Wet the O-ring ② with silicone grease (**Mat. no. 1.000.6403**).



⚠ CAUTION

Damage caused by thermodisinfection.

- ▶ Do not subject the instrument holder to thermodisinfection.



The tumbler filler can be subjected to thermodisinfection.

Sterilisation of the tumbler holder and filler



⚠ CAUTION

Damage caused by sterilisation.

- ▶ Do not sterilise the tumbler holder and filler.

2.6.3 Preparation of the spittoon

Cleaning and disinfection of the spittoon bowl

	⚠ CAUTION
	<p>Damage caused by inappropriate cleaning agents.</p> <ul style="list-style-type: none"> ▶ Do not use acid-containing, sand-containing, and form-forming cleaning agents.

- ▶ Add a dose of DEKASEPTOL gel to the spittoon bowl and distribute the agent with a brush.
- ▶ For cleaning, allow the gel to act for approx. 5 minutes.
- ▶ For disinfection, allow the gel to act for approx. 15 minutes.
- ▶ After letting it work, press the "Spittoon bowl" button.
- ▶ Clean the spittoon bowl thoroughly using a brush.

- ▶ For thorough cleaning or thermidisinfection, rotate the spittoon bowl counter-clockwise and lift it.

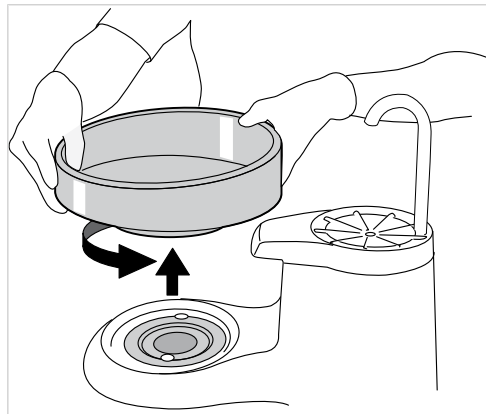

	⚠ CAUTION
	<p>Damage caused by thermidisinfection.</p> <ul style="list-style-type: none"> ▶ Do not subject spittoon bowls made of glass to thermidisinfection.



The spittoon bowl made of porcelain can be subjected to thermidisinfection.

2.7 Automatic hygiene function of the water-conducting system



Note

Intensive disinfection kit required.

	⚠ CAUTION
	<p>Health damage due to germ formation. Infection hazard.</p> <ul style="list-style-type: none"> ▶ Before starting, rinse all the water drain lines without instruments. ▶ Before start-up and after the device has not been used for a while (weekends, holidays, vacations, etc.), rinse or purge with air the air and water lines. ▶ Carry out an intensive disinfection. ▶ Actuate the tumbler filler repeatedly.

The water-conducting system includes all water ducts of the treatment unit to which the patient may be exposed. This includes the instruments on the dentist unit and assistant unit as well as the tumbler filler on the spittoon bowl of the treatment unit. The rinsing programme and the intensive disinfection facilitate automatic rinsing and disinfection of the water-conducting system. Since counteracts the formation of micro-organisms in times of stagnation and ensures hygienic water supply for the patients.

2.7.1 Rinsing programme

Rinsing programme 02 provides for automatic rinsing of the water-conducting system and all instruments including the tumbler filler for 2 minutes each (hydrogen peroxide concentration 0.02 %). In the short rinsing programme 01, all instruments on the dentist unit and assistant unit are rinsed for 20 seconds each.

Carry out the rinsing programme:

- before you start working
- after each patient (short rinsing programme)



- ▶ Briefly press the "Intensive disinfection" button.

Preparation

- ▶ Place the disinfection attachment on the porcelain bowl, or insert it in the glass bowl (depending on the design).

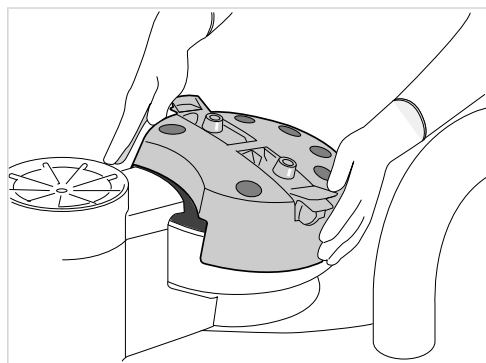

Place the instruments on the sterilisation attachment

The cannulas of the three- and multi-function syringes must be taken off for the rinsing programme and intensive disinfection.

- ▶ Remove the cannula with a slight amount of rotation while holding the tip on the grip sleeve.

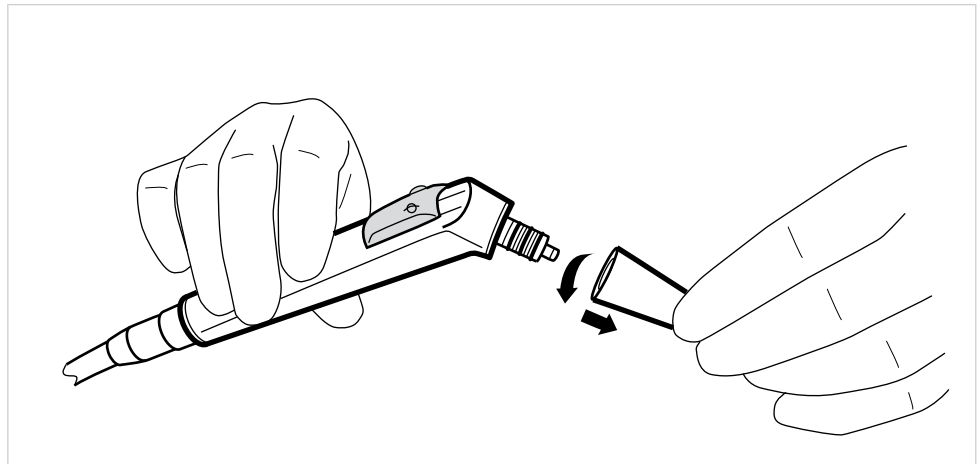

- ▶ Insert three- or multi-function syringes without cannulas in the tightening elements of the disinfection attachment. Make sure that the "W" button (water) of the three-function or multi-function syringes is pressed, and that no air is exiting.
- ▶ Place the instrument hoses of the dentist and assistant units in the provided places of the disinfection attachment.



Note

All water regulation mechanisms for the motor, instruments, and multiflex couplings must be open.

Place the COMFORTbase on the disinfection attachment



Note

A seat adapter (**Mat. no. 1.005.6892**) for the disinfection attachment is available for the COMFORTbase.

- ▶ For the rinsing programme and intensive disinfection, press the seat adapter into one of the four rubber seats of the disinfection attachment.

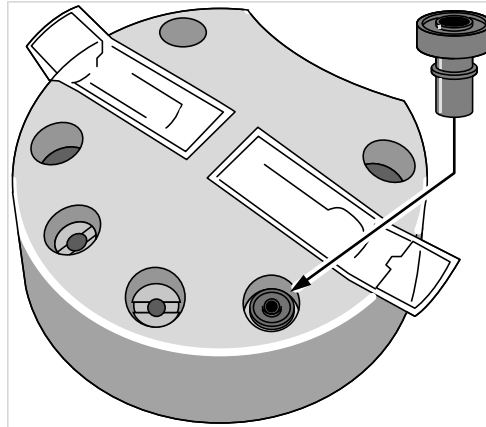

- ▶ Place the COMFORTbase in the seat adapter.

Carry out the rinsing programme

Set rinsing time



With the foot pedal of the foot control being pressed down, the rinsing time for the respective rinsing programme can be set in the range from 0:01 to 4:00 minutes using the "Decrease value" and "Increase value" buttons.

The rinse program proceeds in four steps. For rinse program 01, the cycle starts in step 2, and for rinse program 02, the cycle starts in step 4.

Step	Description
4.0	Fresh water supply 60 seconds
3.0	Tumbler rinsing 20 seconds
2.0	Instrument rinsing The rinsing time can be set variably for each instrument. Standard setting: <ul style="list-style-type: none"> ▪ Rinsing programme 01 = 20 seconds per instrument ▪ Rinsing programme 02 = 2 minutes per instrument
1.0	Rinsing the three- and multi-function syringe set rinsing time of rinsing program 01 or 02
0.1	Waiting position for setting down the instruments

Start rinsing programme



Note

The rinsing program can be started immediately or the next morning.

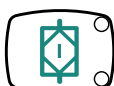

- ▶ Briefly press the "intensive disinfection" key to immediately start the process.

The selected rinse program starts.

or

- ▶ Turn off the device and do not restart it until the next morning.

The cycle is started automatically. The rinsing time follows rinsing program 02.



Note

If the device is not used the entire day (i.e., the instruments are not mounted), the rinsing program automatically starts the next morning when the device is turned on.



The rinsing programme can be stopped at any time by pressing the "intensive disinfection" key.

If the device is turned off and then on again, the rinsing program also stops.

2.7.2 Intensive disinfection



Note

Observe the instructions for use for the instruments.

Intensive disinfection inhibits the formation of microorganisms when the equipment is not used for extended periods of time. During intensive disinfection, the water ducts are automatically filled with a higher concentration of oxygenal. The intensive disinfection programme takes approx. 45 minutes and the increased hydrogen peroxide concentration acts in the system for at least 30 minutes.

An additional intensive disinfection must be carried out during extended periods on non-use (> 4 weeks).

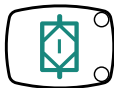

The need for intensive disinfection is automatically displayed in the top LED of the "Intensive disinfection" button at first start-up and after periods of non-use (week-end, holidays, vacation, etc.).

When a beep is issued every 10 seconds and the bottom LED of the "Intensive disinfection" button flashes, Oxygenal must be replenished. If a beep is issued during the filling process (10 times each second), the container is full.



Note

The suction cannot be used while the HYDROclean step (4.6) is in progress.



Note

If the amalgam separator malfunctions during intensive disinfection, the entire process is stopped. The bottom LED of the "HYDROclean" button flashes.

Intensive disinfection must be carried out:

- At first start-up
- After periods of non-use
- Over the weekend
- During vacations

Start intensive disinfection

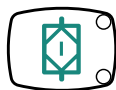

- ▶ Press the "Intensive disinfection" button until you hear a beep and the top LED flashes. The display changes to the intensive disinfection menu.



- ▶ Prepare for intensive disinfection.
- ▶ Press the "Intensive disinfection" button.

Intensive disinfection starts and proceeds through several stages. The process can be followed in the display. The major steps are listed below.

Step	Description
7.0	Disinfection of the three- and multi-function syringe and spittoon bowl 60 seconds
6.0	Instrument disinfection 30 seconds each
5.0	Tumbler disinfection 40 seconds
4.0	Dwell time (signal sound, the process can be shut off) 30 minutes
3.0	Tumbler rinsing 40 seconds
2.0	Instrument rinsing 30 seconds
1.0	Rinsing the three- and multi-function syringe 30 seconds
0.1	Waiting position for setting down the instruments

Intensive disinfection is completed when "01 intensive disinfection completed" appears on the display.

- ▶ Reinsert all instruments and remove the holder.

Interrupt intensive disinfection during the dwell time

So that no one will have to remain with the device throughout the entire intensive disinfection process, intensive disinfection can be interrupted in programme step 4 (dwell time in which the microorganisms are killed by an increased oxygenal concentration) (such as on the last workday before the weekend).

- ▶ Turn off the unit when the intensive disinfection program is in step 4 (an audible signal sounds for 4 seconds).

When the device is switched on after 30 minutes of dwell time, the remaining programme steps run immediately.

If the device is turned on before the 30 minutes are over, the dwell time finishes first before the remaining steps of the intensive disinfection program run.

Skip exposure phase

This function is required when the disinfection procedure has already been started and the treatment unit needs to be used (for example in an emergency, at hospitals, etc.).

Intensive disinfection is in step 4:

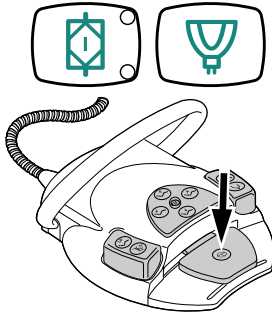

- ▶ Press and hold down the "Intensive disinfection" button and the "Hydrocolloid" button.
- ▶ Simultaneously press the foot pedal on the foot control.

The intensive disinfection switches to step 3.7.
The automatic rinsing process starts up.

Intensive disinfection during extended periods of non-use (> 4 weeks)

During extended periods of non-use, e.g. semester breaks at university, intensive disinfection is carried out during the time of non-use. The disinfection fluid remains inside the system during the period of non-use.

Before the period of non-use

- ▶ Start the intensive disinfection and stop it in step 4 after the signal sound during the dwell time of 30 minutes.
- ▶ To prevent damage due to hoses getting kinked, remove hoses from the disinfection attachment and place them in the dentist support.
- ▶ Keep the disinfection attachment in the spittoon bowl.
- ▶ Cover the treatment unit during extended periods of non-use.

After the period of non-use

- ▶ Turn on the central compressor.
- ▶ Once the system pressure is established, turn on the central water supply for the treatment unit.
- ▶ Replace the instrument hoses of the dentist and assistant units in the places provided in the disinfection attachment.
- ▶ Turn the treatment unit on.

The unit automatically starts the remaining steps of the unfinished cycle.

- ▶ Allow the cycle to complete and then carry out a second full intensive disinfection.

The unit is now ready for use.

Additional intensive disinfection during period of non-use

KaVo recommends carrying out an additional intensive disinfection at universities during semester breaks. This flushes the parts of the unit and replaces the disinfection liquid.

2.8 Reprocessing and automatic hygiene functions of the suction system

2.8.1 Reprocessing of the suction system including suction hoses

Cleaning and disinfection of the suction system including suction hoses



Note

Clean the suction hoses after each treatment and disinfect them with DEKASEPTOL Gel daily.

Application of DEKASEPTOL Gel

- ▶ Aspirate one tumbler of cold water with each suction hose.
- ▶ With the suction handpiece attached or by hand, press down the DEKASEPTOL dosing facility once each for the saliva ejector hose and the spray mist ejector.
- ▶ Aspirate DEKASEPTOL Gel from the dosing facility.
- ▶ Aspirate another tumbler of cold water with each suction hose.
- ▶ Then aspirate another dose of DEKASEPTOL Gel and allow to act.
- ▶ Place the suction hoses in the holder.

DEKASEPTOL Gel Basis Set	DEKASEPTOL Gel replacement canister
Mat. no. 1.000.7204	Mat. no. 1.000.7205

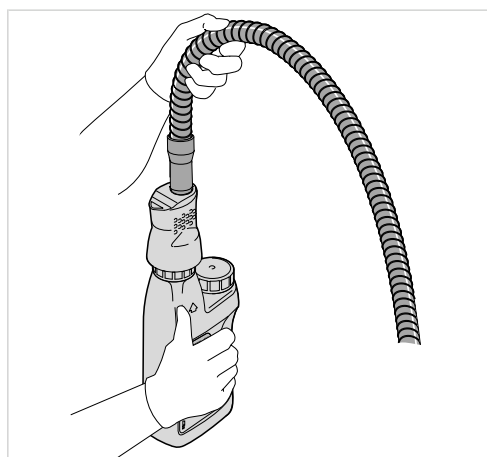

2.8.2 HYDROclean function

The HYDROclean function is an automatic programme for hydromechanical cleaning of the drainage and separation systems within and outside the treatment unit

through the supply of fresh, clear water (limited rinsing). The water is sucked out of the Aquamat through the filter housing to the separation system. The spittoon bowl rinsing is alternately turned on and off.

The HYDROclean function prevents the coagulation and adhesion of proteins inside the drainage system and improves the transport of fine particles.

Requirement

Suction hoses remain hanging in the holder.

Start the HYDROclean function

- ▶ Press the "HYDROclean" button.

HYDROclean is in the preparation stage.



- ▶ Press the "HYDROclean" button.

This starts-up the HYDROclean function.

The top LED goes dark when the process is completed.



The process can be discontinued at any time by pressing the "HYDROclean" button.

2.9 Preparation of the amalgam separator

You can use a "Dürr" amalgam separator or an "external suction kit for connecting to a central amalgam separator" or a separation kit.

Optimal care of the amalgam separation system includes the correct and regular use of the HYDROclean function as well as the care of the suction hoses and spittoon bowl.

**Note**

follow the instructions for use for the amalgam separator.

3 Replenish and check the disinfectant

3.1 Replenish oxygenal

In KaVo water disinfection systems, only oxygenal (**Mat. no. 0.489.3451**) may be used. The oxygenal consumption depends on the water consumption during the treatment of patients.

When the oxygenal container is empty, a signal sound is issued every 10 seconds.



Note

Replenish oxygenal only if the acoustic signal is issued every 10 seconds. The signal can be turned off: Hold down the control pedal, and move the backrest up and down. The next time the treatment unit is turned on, the signal sound is issued again.

- ▶ Remove the tumbler filler ① and tumber holder ②.



- ▶ Top off the oxygenal (max. 1 litre)



Note

Do not fill through the centre opening (tumbler drain). Do not fill through the centre opening (tumbler drain).

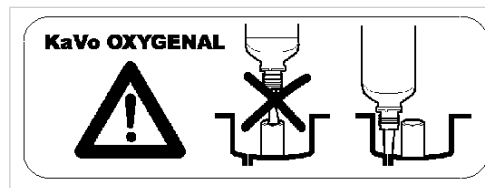

- ▶ Quit replenishing immediately once a signal sound is issued every second (10 sounds).

Reservoir is full.

- ▶ Attach the tumbler holder and the tumbler filler.



Note

Check the O-ring on the tumbler filler for damage.

3.1.1 Refilling oxygenal when using the water bottle

	<p>⚠ CAUTION</p>
	<p>Damage caused by defective water bottle. Malfunctions or failures from a leaky water bottle.</p> <ul style="list-style-type: none"> ▶ Do not wash the water bottle in a dish washer, and do not rinse it with water hotter than 50 °C. ▶ Do not use the water bottle if it is scratched, deformed or discoloured. ▶ Note the maximum useful life of the water bottle on the label.

Water bottle complete: (Mat. no. 0.710.4151)

Dosing attachment: (Mat. no. 1.002.0287)

Removing and cleaning the water bottle

- ▶ Slowly turn the water bottle counterclockwise to take it off.

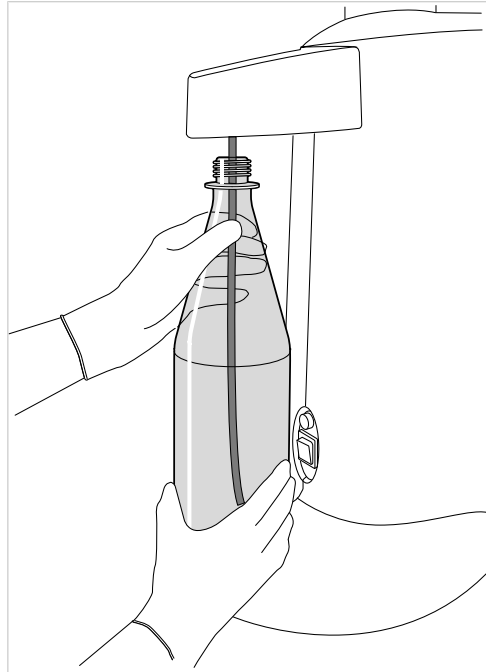

Note

This allows the over-pressure to be released slowly from the water bottle.



⚠ CAUTION

Damage caused by inappropriate cleaning of the water bottle.
The material of the water bottle is destroyed.

- ▶ Do not rinse the water bottle with water hotter than 50°C.
- ▶ Do not clean the water bottle in the dish washer.

- ▶ For cleaning, rinse the water bottle with water at less than 50 °C.

Filling the water bottle with the dosing facility.

- ▶ Remove the protective hose from the tube of the oxygenal dosing facility.
- ▶ Guide the tube through the orifice of the coarse sieve of the oxygenal bottle.

- ▶ Screw the oxygenal dosing facility tightly onto the oxygenal bottle.

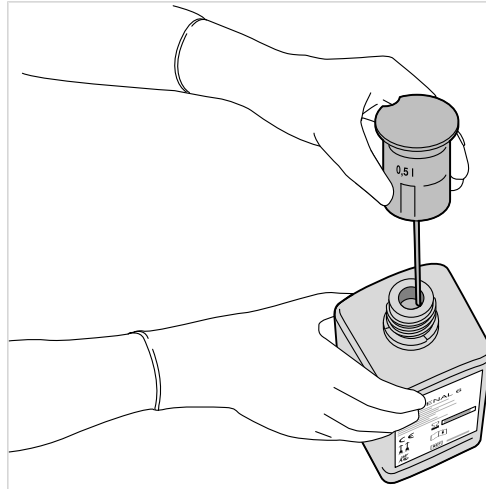

- ▶ Rotate the orifice in the lid to a filling level of 1.5 litres.

Lid snaps-in in the filling position.



- ▶ Place the oxygenal bottle on a level surface.
- ▶ Press the lid down until the dosing quantity is over-filled.

In response to over-filling, the excess quantity above the tick mark is suctioned off automatically such that exact dosing is ensured.



- Fill the water bottle from the oxygenal bottle. Make ensure that the pouring opening of the oxygenal dosing facility (spout) is right above the opening of the water bottle.

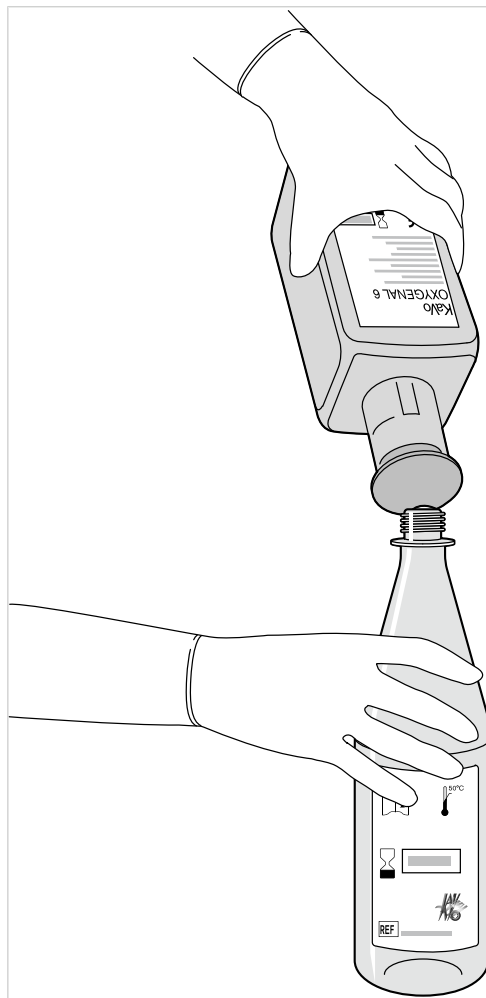



Note

Substances remaining in the dosing head are not contamination, but rather agents that are deposited there during extended periods of non-use after condensation of the water. These deposits redissolve after several dosing processes.

3.2 Checking the oxygenal concentration

- ▶ Fill the tumbler with water.
- ▶ Use Merckoquant peroxide test strips 100 through 1000 mg/l H₂O₂ (Merck article number: 1100337) to determine the oxygenal concentration in the water disinfection system.

The oxygenal concentration in normal operation should be between 150 and 250 mg/l H₂O₂.



KaVo. Dental Excellence.