

Instructions for use

KaVo Primus® 1058 S/TM/C/G



Always be on the safe side.



KaVo. Dental Excellence.

Sales:
KaVo Dental GmbH
Bismarckring 39
D-88400 Biberach
Tel. +49 7351 56-0
Fax +49 7351 56-1488

Manufacturer:
Kaltenbach & Voigt GmbH
Bismarckring 39
D-88400 Biberach
www.kavo.com



Contents

Contents	1
1 User instructions	3
1.1 User guide	3
1.1.1 Abbreviations	3
1.1.2 Symbols	3
1.1.3 Target group	3
1.2 Service	4
1.3 Warranty terms and conditions	5
1.4 Transportation and storage	6
1.4.1 Currently valid packaging ordinance	6
1.4.2 Damage in transit	6
1.4.3 Information on the packaging: Storage and transport	8
2 Safety	9
2.1 Description of safety instructions	9
2.1.1 Warning symbol	9
2.1.2 Structure	9
2.1.3 Description of danger levels	9
2.2 Purpose - proper use	10
2.2.1 General information	10
2.2.2 Product-specific	12
2.3 Safety instructions	13
2.3.1 General information	13
2.3.2 Product-specific	13
3 Product description	15
3.1 Treatment unit versions	15
3.1.1 KaVo Primus® 1058 S	15
3.1.2 KaVo Primus® 1058 TM	15
3.1.3 KaVo Primus® 1058 G	16
3.1.4 KaVo Primus® 1058 C	16
3.1.5 KaVo Primus® 1058 C with right-side set-up kit	17
3.2 Patient chair/ COMPACTchair patient chair	18
3.3 Device body with patient unit	19
3.4 Dentist unit	20
3.5 Assistant unit	22
3.6 Key fields	23
3.6.1 with Comfort dentist unit and assistant unit	23
3.6.2 Standard assistant unit	24
3.7 Multifunctional foot control	26
3.8 Technical data	27
3.9 Rating plate and identification plate	30
4 Operation	33
4.1 Turn the unit on and off	33
4.2 Adjusting the patient chair	34
4.2.1 Adjust the arm rest	34
4.2.2 Adjust the seat	35
4.2.3 Adjust head rest	36
4.2.4 Adjust chair position	41
4.2.5 Safety shut-off	47
4.3 Move the dentist's unit	51
4.3.1 Move the cart	52

Contents

4.4 Move the patient unit	54
4.4.1 Swing the patient unit by hand	54
4.5 Adjust the height of the assistant unit	55
4.6 Setting functions	56
4.6.1 Select memory level Dentist 1 or Dentist 2	56
4.6.2 Fill the tumbler and rinse the spittoon	56
4.6.3 Turn the x-ray image viewer on and off	57
4.6.4 Turn the treatment light on and off using the cold light button	58
4.6.5 Set the time and use the timer (only with Memospeed)	58
4.6.6 Using the function keys	59
4.7 Using instruments	60
4.7.1 Save instrument-specific settings	60
4.7.2 Using the turbine	61
4.7.3 Using the INTRA LUX motor K 200/KL 701 and COMFORTdrive 200XD	64
4.7.4 Operating the PIEZOlux	66
4.7.5 Using the triple and multifunction handpiece	69
4.7.6 Adjusting the suction	71
5 Preparation methods DIN EN ISO 17664	74
6 Accessories and kits	75
6.1 Unit base	75
6.2 Patient chair	76
6.3 Patient unit with device body and assistant unit	77
6.4 Dentist unit	78
7 Troubleshooting	79
8 Do safety checks	81
8.1 Measure the protective conductor resistance	81
8.2 Measure equivalent unit leakage current	85
8.3 Measure equivalent patient leakage current	87
9 Data on electromagnetic compatibility according to EN60601-1-2	88
9.1 Electromagnetic Transmissions	88
9.2 Resistance to electromagnetic interference	89
9.3 Recommended safe distance between portable and mobile HF telecommunications equipment and the PRIMUS 1058	92

1 User instructions

1.1 User guide





Requirement

Read these instructions prior to first use to prevent misuse and damage.

1.1.1 Abbreviations

Short form	Explanation
GA	Instructions for use
PA	Care instructions
MA	Assembly instructions
TA	Technician's instructions
STK	Safety check
IEC	International Electrotechnical Commission
RA	Repair instructions
EMC	Electromagnetic compatibility

1.1.2 Symbols

	See the section Safety/Warning Symbols
	Important information for users and technicians
	CE mark (Communauté Européenne). A product with this mark meets the requirements of the applicable EU directive.
	Action required

1.1.3 Target group

This document is for dentists and office personnel.

1.2 Service



Service hotline:

++ 49 (0) 7351 56-2500

Service.Einrichtungen@kavo.com

Please indicate the product serial number in all requests.

Additional information can be obtained at: www.kavo.com

1.3 Warranty terms and conditions

KaVo provides the end customer with a warranty that the product cited in the hand-over certificate will function properly and guarantees zero defects in the material or processing for a period of 12 months from date of purchase, subject to the following conditions:

In the event of justified complaints due to defects or short delivery, KaVo may choose to fulfil the terms and conditions of the warranty either by supplying a replacement product free of charge or repairing the defective product. Other claims of any nature whatsoever, in particular with respect to compensation, are excluded. In the event of default and gross negligence or intent, this shall only apply in the absence of mandatory legal regulations to the contrary.

KaVo cannot be held liable for defects and their consequences due to natural wear, improper cleaning or maintenance, non-compliance with operating, maintenance or connection instructions, calcination or corrosion, contaminated air or water supplies or chemical or electrical factors deemed abnormal or impermissible in accordance with factory specifications.

The warranty does not usually cover bulbs, glassware, rubber parts and the colour-fastness of plastics.

Defects or their consequences that can be attributed to interventions on or changes made to the product by the customer or a third party are excluded from the warranty. Claims from this warranty can only be asserted when the transfer form (copy) belonging to the product has been sent to KaVo, and the original can be presented by the operator or user.

1.4 Transportation and storage

1.4.1 Currently valid packaging ordinance



Note

Only applicable for the Federal Republic of Germany.

KaVo transport packaging must be disposed of and recycled by local disposal service providers and recycling companies in accordance with Dual System requirements.

For more information about disposal and recycling, and an up-to-date list of local disposal service providers and recycling companies, please visit the following Internet sites:

<http://www.umweltdatenbank.de>

<http://www.quality.de>

KaVo will bring KaVo transport packaging returned by the customer at the customer's own cost to the appropriate recycling companies without reimbursement..

1.4.2 Damage in transit

In Germany

If external damage to the packaging is visible upon delivery, follow the procedure below:

1. The recipient must record the loss or damage in the notice of delivery. The recipient and employee of the transportation firm must sign the notice of delivery.
2. Leave the product and packaging unchanged.
3. Do not use the product.
4. Report damage to the shipping company.
5. Report damage to KaVo.
6. A damaged product cannot be returned before talking with KaVo.
7. Send the signed notice of delivery to KaVo.

If the product is damaged and there is no discernable damage to the packaging upon delivery, proceed as follows:

1. Report damage immediately or at least 7 days after the delivery to the delivery company.
2. Report damage to KaVo.
3. Leave the product and packaging unchanged.
4. Do not use a damaged product.



Note

If the recipient does not follow one of the above instructions, the damage will be held to have occurred after the delivery (according to ADSp. Art. 28)..

Outside of Germany



Note

KaVo is not liable for damage arising from transportation.
Immediately inspect the delivery after receipt!

If external damage to the packaging is visible upon delivery, follow the procedure below:

1. The recipient must record the loss or damage in the notice of delivery. The recipient and employee of the transportation firm must sign the notice of delivery. The recipient can only assert damages against the transportation company based on these records.
2. Leave the product and packaging unchanged.
3. Do not use the product.

If the product is damaged and there is no discernable damage to the packaging upon delivery, proceed as follows:

1. Report the damage immediately or at least 7 days after the delivery to the delivery company .
2. Leave the product and packaging unchanged.
3. Do not use a damaged product.



Note

If the recipient does not follow one of the above instructions, the damage will be held to have occurred after the delivery (according to . CMR law , section 5, Art. 30).

1.4.3 Information on the packaging: Storage and transport



Note

Keep the packaging for returning the product for service or repairs .

The symbols printed on the outside are for transportation and storage, and have the following meaning:

	Transport upright with the arrows pointing upwards
	Fragile - protect against knocks
	Keep dry
	Permissible stacking load
	Temperature range
	Humidity
	Air pressure

2 Safety

2.1 Description of safety instructions

2.1.1 Warning symbol



Warning symbol

2.1.2 Structure



The introduction describes the type and source of the hazard.

This section describes the potential consequences of non-observance.

- ▶ The optional step contains necessary measures for avoiding hazards.

2.1.3 Description of danger levels

The safety instructions cited herein with the three levels of danger will help avert property damage and injury.



CAUTION

indicates a hazardous situation that can lead to property damage or minor to moderate injury.



WARNING

indicates a hazardous situation that can lead to serious injury or death.



DANGER

indicates a maximum hazardous situation that can directly cause serious injury or death.

2.2 Purpose - proper use

2.2.1 General information

The user must ensure that the device works properly and is in a satisfactory condition before each use.

The KaVo Primus 1058 system is a dental treatment unit in accordance with ISO 7494 that has a dental patient chair in accordance with ISO 6875. This KaVo product is for dental purposes only and should only be used by medical professionals. The product may not be used for a purpose for which it was not intended.

"Proper use" includes following all the instructions for use and ensuring that all inspections and service tasks are performed.

Apply and meet the overarching guidelines and/or national laws, national regulations and the rules of technology for medical devices applicable for startup and use of the KaVo product for the intended purpose.

Responsibility is accepted for the safety, reliability and performance of the components supplied by KaVo provided:

- installation, upgrades, adjustments, changes or repairs are carried out by technicians trained by KaVo or third parties authorised by KaVo, or by the personnel of authorised distributors.
- The unit is operated in accordance with the instructions for use, care and installation.
- The IT components supplied by the operator meet the technical requirements in these instruction for use for hardware and software, and they are installed and set up according to the descriptions of these components.
- If it is repaired, the requirements of VDE 0751-1 "Repeat tests and tests before start-up of electrical items of medical equipment and systems - general regulations" must be met in full.

The user must observe the following:

- - only use properly operating equipment.
- protect himself or herself and third parties from danger.
- avoid contamination from the product.

During use, national legal regulations must be observed, in particular:

- the applicable health and safety regulations.
- the applicable accident prevention regulations.

To ensure that KaVo products maintain their value and are always ready for use, they must be serviced once a year as recommended.

The safety checks must be performed every two years.

Authorised to repair and service the KaVo product:

- Technicians from the KaVo branches who are trained to deal with the product.
- the technicians of the KaVo franchised dealers specifically trained by KaVo.

In Germany, the operator, person responsible for the device and user must operate their devices in accordance with the provisions of the Medical Device Law. These service tasks include all testing tasks that are stipulated in the Operator Ordinance (MPBetreiber V) § 6.



Note

The product must be cleaned and serviced according to instructions if it is not to be used for a long period.



Note

Only those accessories may be used that are approved for the device.

Information on electromagnetic compatibility



Note

Based on EN 60601-1-2 concerning the electromagnetic compatibility of electro-medical devices, we need to point out that:

- medical electrical devices are subject to special measures regarding electromagnetic compatibility and must be operated in accordance with KaVo assembly instructions.
- portable and mobile high-frequency communications devices can influence medical electronics.



Note

KaVo cannot guarantee that accessories, lines and transformers not delivered by KaVo will correspond with EMC requirements of EN 60601-1-2.

Disposal



Note

The waste that arises must be recycled or disposed of in a manner safe for humans and the environment. Observe the applicable national regulations. Please direct all questions regarding the proper disposal of KaVo products to the nearest KaVo branch.

Disposal of electronics



Note

According to EC directive 2002/96 concerning used electrical and electronic devices, this product is subject to the cited directive and must be disposed of accordingly within Europe. Before disassembling / disposing of the product, it must be completely processed (disinfected, sterilized) according to the section "Preparation methods" Additional information can be obtained from KaVo (www.kavo.com) or your dental supplier.

2.2.2 Product-specific

Use and target group



Note

Only trained professionals and cleaning personnel may be present in the treatment rooms.

The KaVo Primus 1058 S/TM/C/G is for treating children and adults in the field of dentistry.

The device may only be used by medical professionals.

For technician jobs that require greater pressure than when working in the oral cavity such as grinding prostheses, etc., a special technician's machine must be used. The bearings of these machines are correspondingly stronger.

2.3 Safety instructions

2.3.1 General information

The KaVo product is not permitted to be used in areas subject an explosion hazard.



Premature weary and malfunctions from improper servicing and care.

Reduced production time.

- ▶ Perform regular proper care and maintenance.



Injury or damage from damaged functional parts.

When functional parts are damaged, it can cause additional damage or personal injury.

- ▶ When operating parts are damaged: Stop working and eliminate the damage or notify a service technician.
- ▶ Check the electrode lines and accessories for damage to the insulation.



Risks from electromagnetic fields.

The functions of implanted systems (such as pacemakers) can be influenced by electromagnetic fields.

- ▶ Ask patients before treatment.



Malfunctions due to electromagnetic fields.

The product meets the applicable requirements regarding electromagnetic fields. Given the complex interactions between equipment and cell phones, the product may be influenced by a cell phone that is in use.

- ▶ Do not use cell phones in medical offices, hospitals, or laboratories.
- ▶ Put electronic devices such as e.g. computer storage media, hearing aids etc. down during operation .

2.3.2 Product-specific



Moving the dentist's unit or the assistant's unit.

The patient or treatment personnel may be injured or crushed.

- ▶ Monitor the patient and treatment personnel when moving the dentist's unit.



Germ formation.

Infections.

- ▶ Before starting, rinse all the water drain lines without instruments.
- ▶ Before start-up and after the device has not been used for a while (weekends, holidays, Leave etc.), rinse or purge the air and water lines.
- ▶ Run intensive sterilisation.
- ▶ Actuate the tumbler filler several times.



Stickers can damage the instrument hoses.

Instrument hoses can rupture.

- ▶ Do not affix stickers or adhesive tape.



CAUTION

Long stay in the patient chair.

Decubitus formation.

- ▶ Take precautions against the formation of decubitus in long treatments.



WARNING

Injury or infection hazard from laid down instruments.

Given the arrangement of the instruments, injury or infections in the hand and underarm can arise when reaching for the tray holder or operating device. Increased risk of infection from diseased patients.

- ▶ Be aware of the arrangement of the instruments when accessing the tray holder or operating device.



CAUTION

Danger of injury from tipping the treatment unit.

Injury to the patient and user.

- ▶ Do not support yourself on the swinging arm.
- ▶ Do not sit on the head or foot end of the patient chair when it is in a horizontal position.



CAUTION

Danger of injury from overload

The patient chair can collapse

- ▶ Do not subject the patient chair to a load above its limit (135 kg).

3 Product description

3.1 Treatment unit versions

3.1.1 KaVo Primus® 1058 S

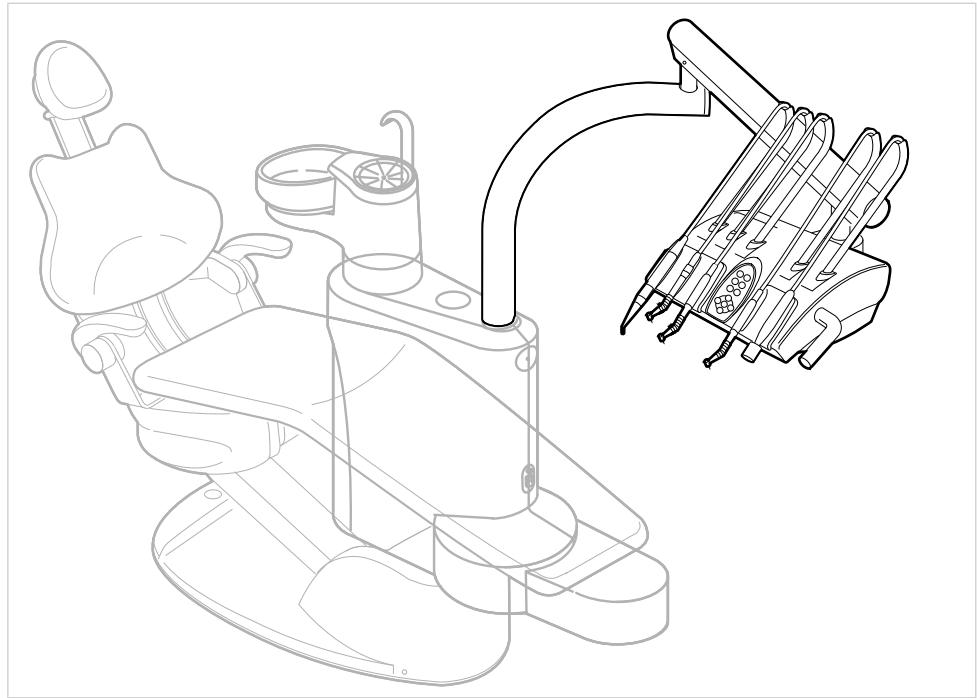

3.1.2 KaVo Primus® 1058 TM

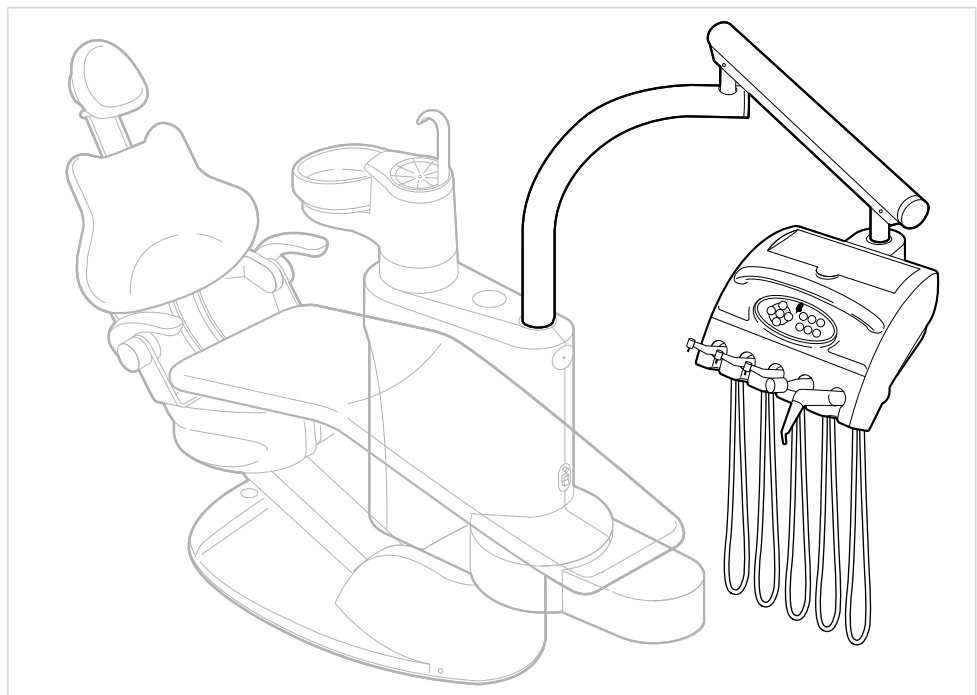

3.1.3 KaVo Primus® 1058 G

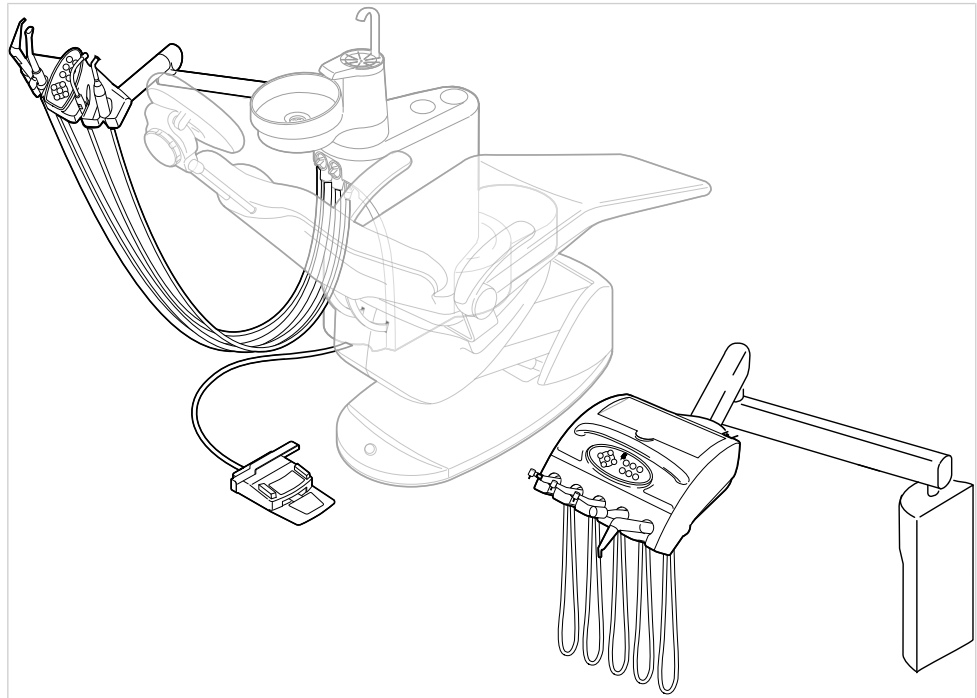

3.1.4 KaVo Primus® 1058 C

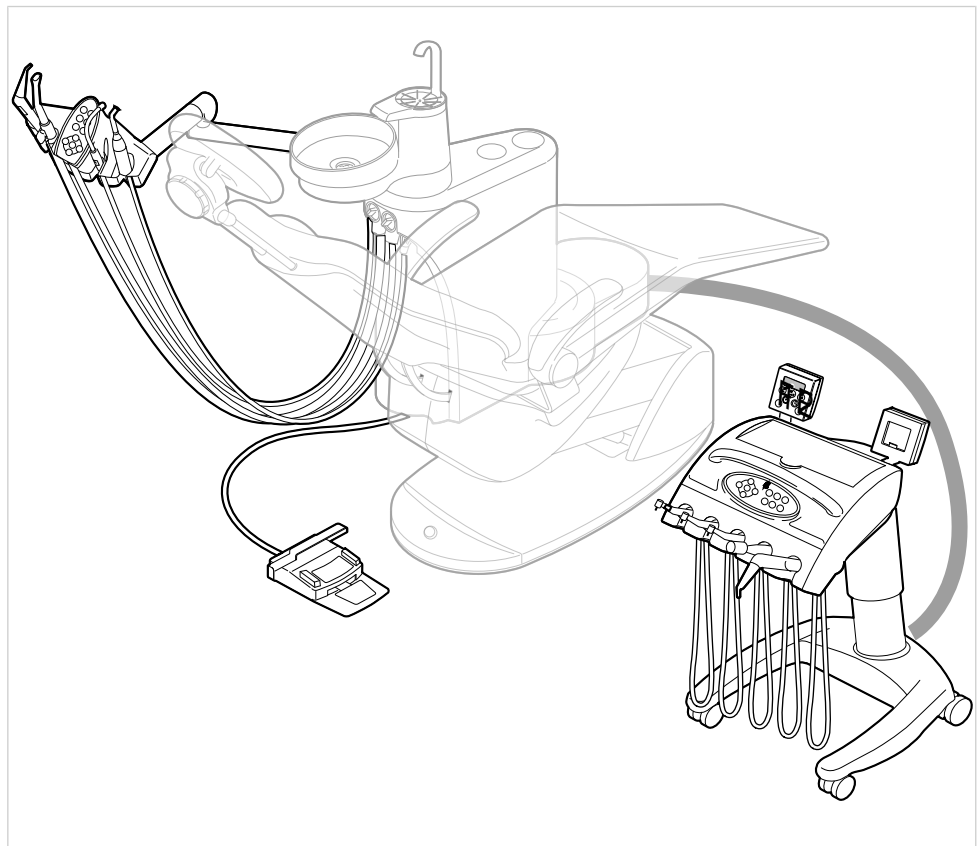

3.1.5 KaVo Primus® 1058 C with right-side set-up kit.

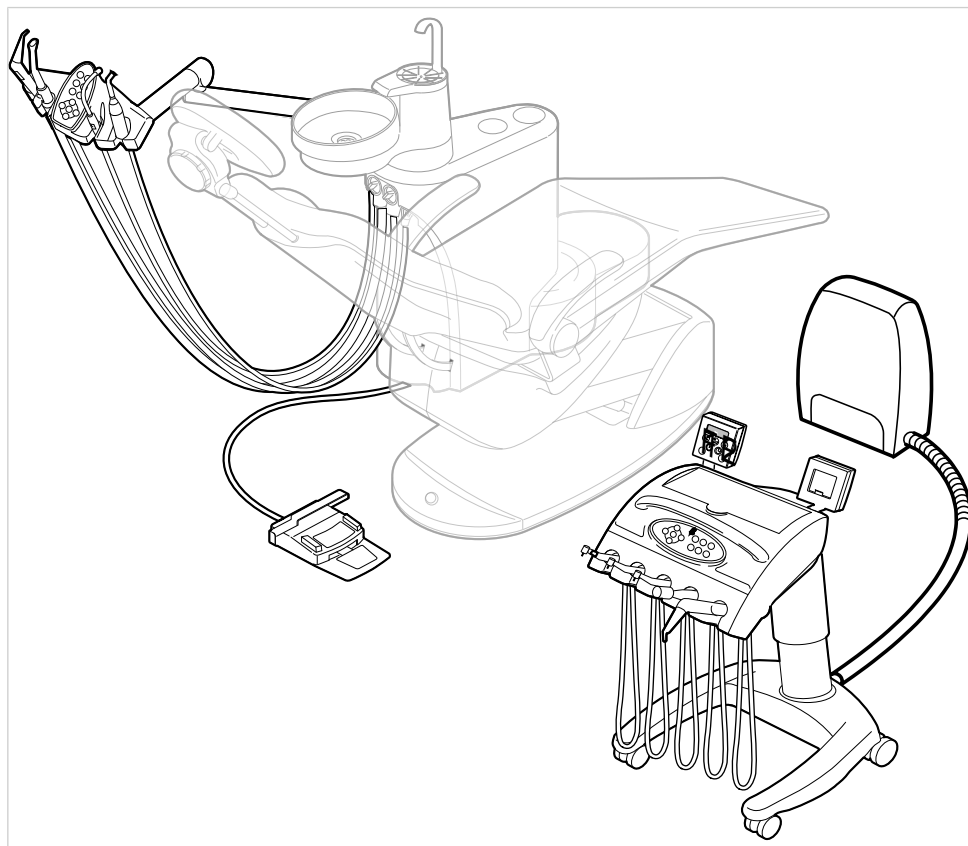

3.2 Patient chair/ COMPACTchair patient chair

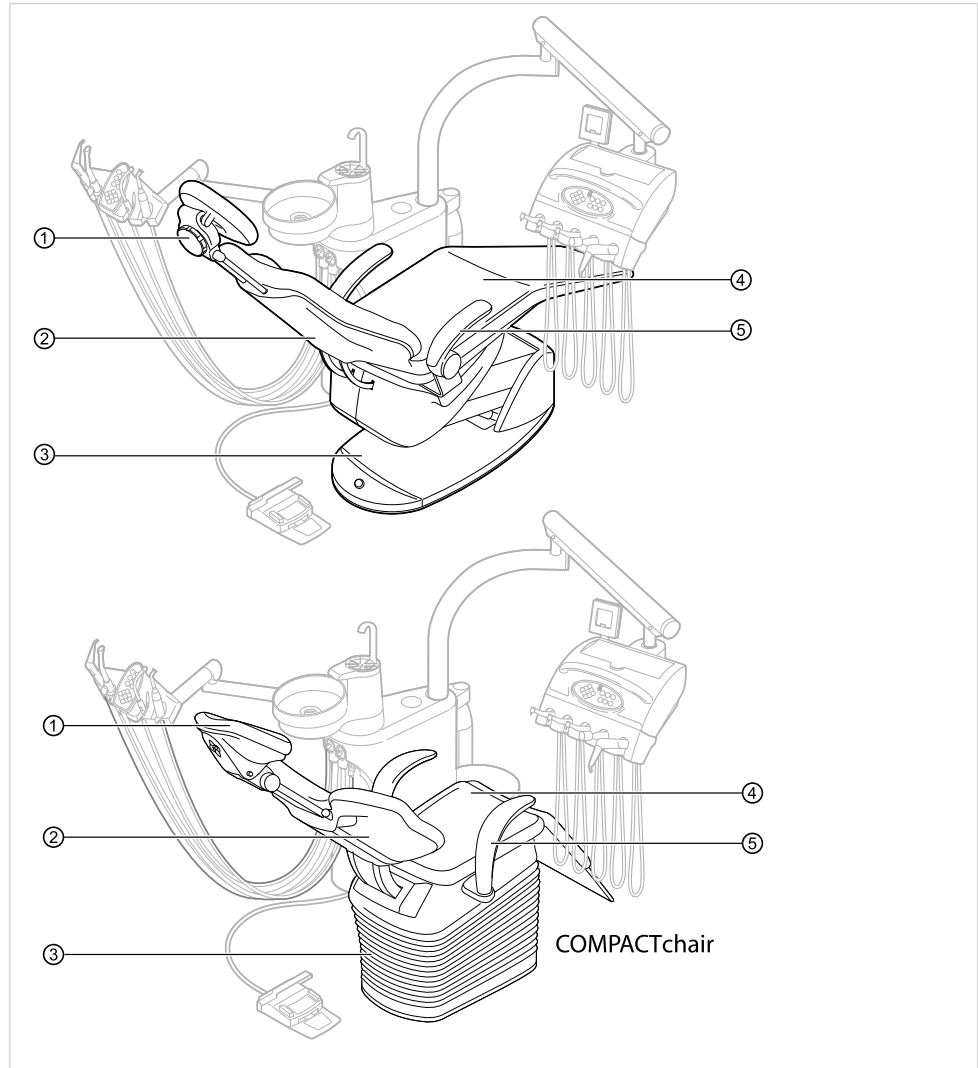

- ① Headrest
- ② Backrest
- ③ Chair base

- ④ Seat
- ⑤ Arm rest

3.3 Device body with patient unit

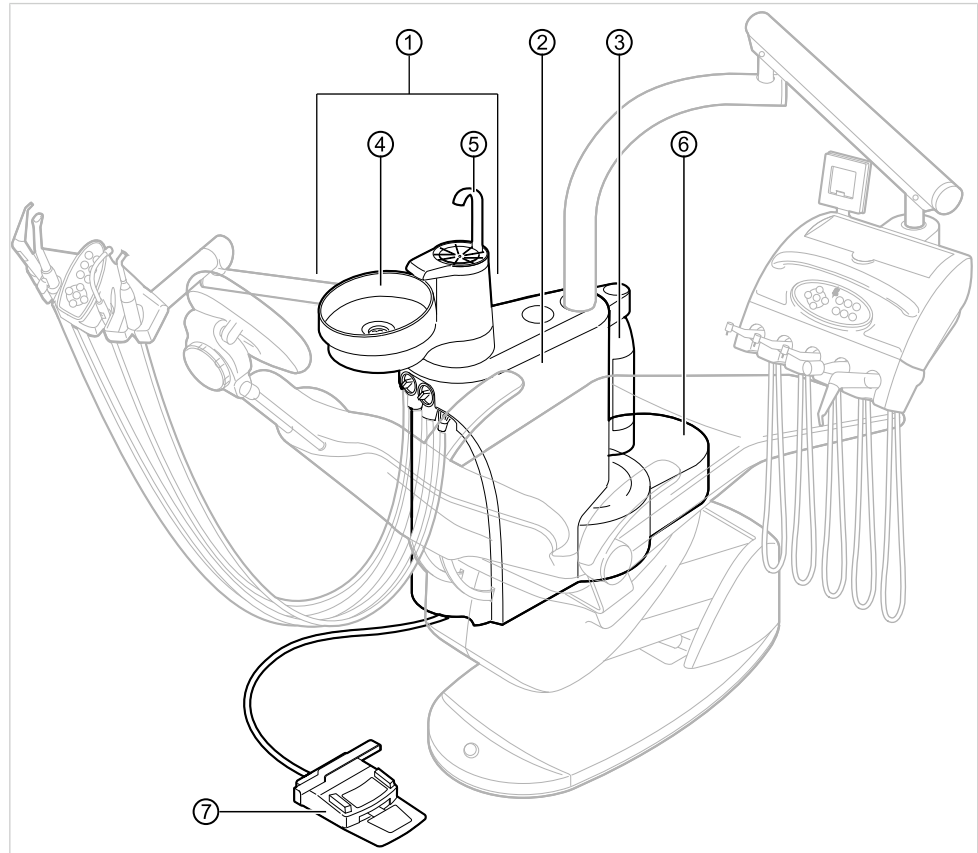

Device body with patient unit

- | | |
|---|--|
| ① Patient unit | ⑤ Tumbler filler |
| ② Device body
The central control is in the device body. | ⑥ Supply unit
Customer connection of power, water, compressed air, wastewater and suction air |
| ③ Pressurized water bottle (extra) | ⑦ Multifunctional foot control |
| ④ Spittoon | |

3.4 Dentist unit



Note

The arrangement of the instruments can be changed if needed.

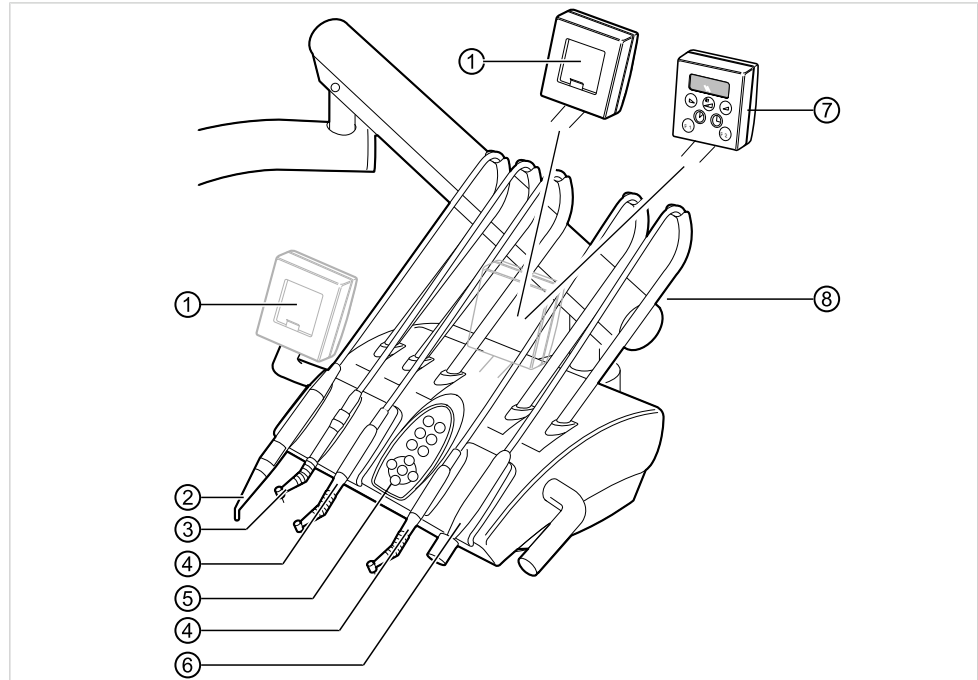

1058 S

- | | |
|---|----------------------------|
| ① small X-ray viewer | ⑤ Button and display field |
| ② Triple-function handpiece or multi-functional handpiece | ⑥ PIEZOlux |
| ③ Turbine | ⑦ Memospeed |
| ④ Either the INTRA LUX K 200, KL 701 motor, or the COMFORTdrive 200XD | ⑧ brake |

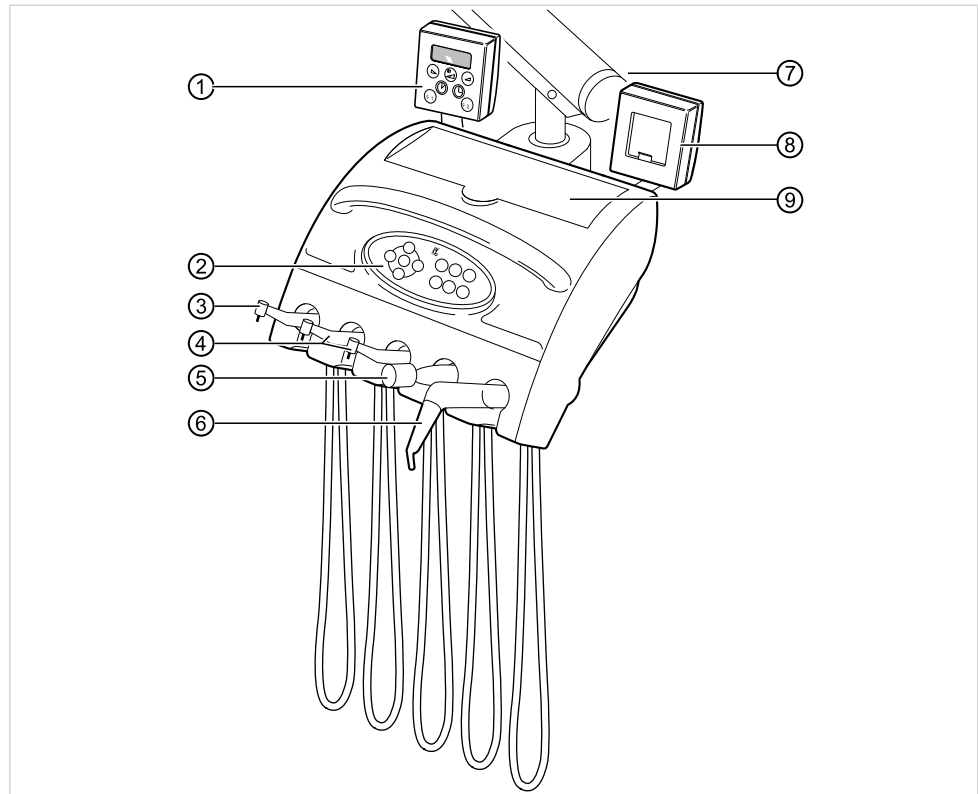

1058 TM/C/G

- | | |
|---|---|
| ① Memospeed | ⑥ Triple-function handpiece or multi-functional handpiece |
| ② Button and display field | ⑦ brake |
| ③ Turbine | ⑧ small X-ray viewer |
| ④ Either the INTRA LUX K 200, KL 701 motor, or the COMFORTdrive 200XD | ⑨ Tray holder |
| ⑤ PIEZOlux | |

KaVo recommends only using the tablet tray (**Mat. no. 0.228.3016**) on the tray holder ⑨ to protect the painted parts on the dentist unit.

3.5 Assistant unit

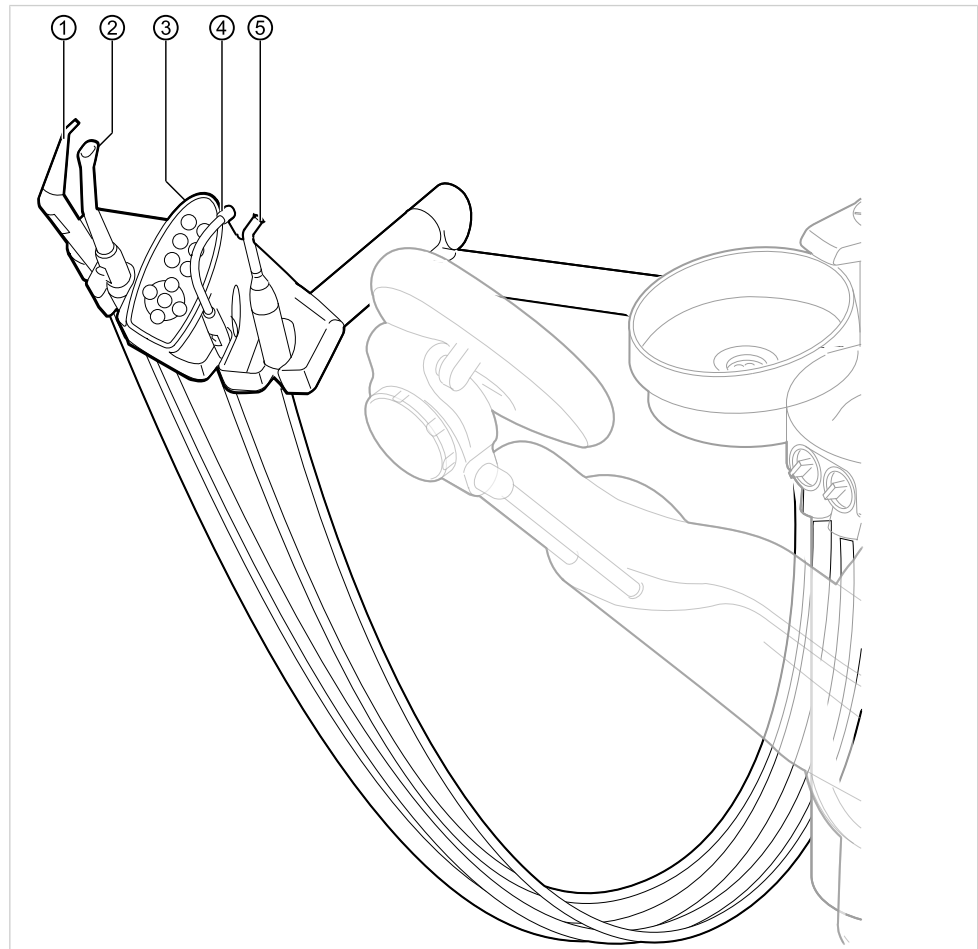

- ① Triple-function handpiece or multi-functional handpiece
- ② Spray mist suction
- ③ Comfort button and display field

- ④ Saliva ejector
- ⑤ Satelec Mini LED

3.6 Key fields



Note

The key functions on the 1058 S/TM/C/G dentist unit and Comfort assistant unit are the same. The key fields are arranged differently due to the different shape.

3.6.1 with Comfort dentist unit and assistant unit

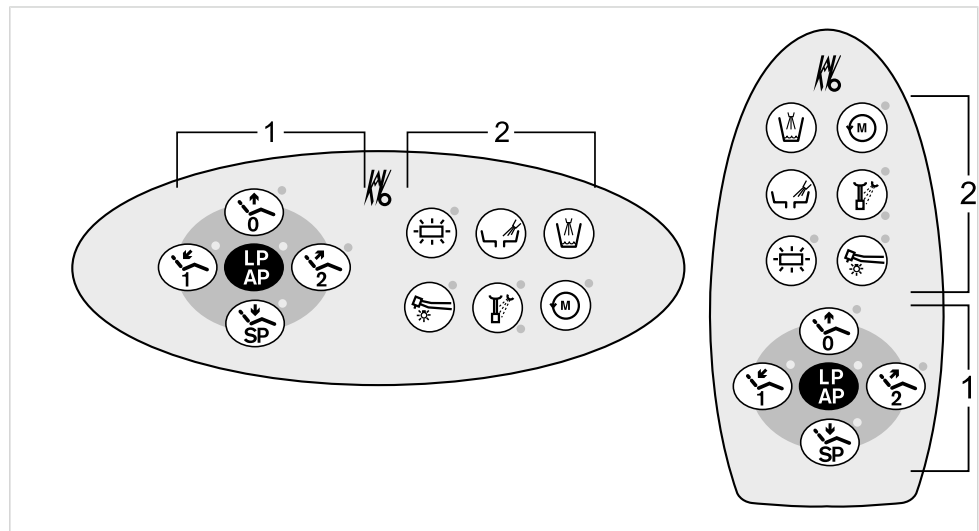







① Patient chair

② function keys

Group of keys for the patient chair

Key	Designation	Display LED
	Seat up/AP 0 (automatic position 0)	green
	Seat down/rinsing position	green
	Backrest down/ AP 1 (automatic position 1)	green
	Backrest up/ AP 2 (automatic position 2)	green
	Last position/automatic position	green

Group of function keys

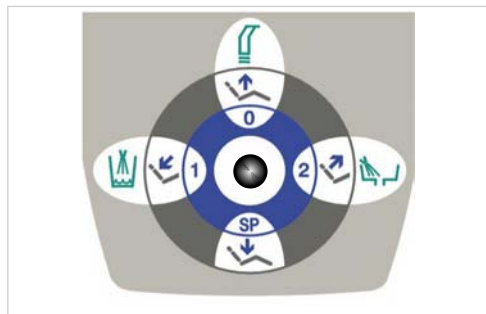

Key	Designation	Display LED
	X-ray viewer	green
	Rinsing the spittoon	
	Tumbler filler	
	Cold light (on instruments)/ Treatment unit ON when the instruments are moun- ted	green
	Spray preselection (on re- moved instruments)	green/yellow
	Counterclockwise motor rotation	red

3.6.2 Standard assistant unit





Note

Each direction of the joystick has several functions.

Joystick in direction	operation
	Seat up AP 0 (automatic position 0) Suction on/off
	Seat down Rinsing position Suction on/off
	Seat-back up AP 2 Rinsing the spittoon

3 Product description | 3.6 Key fields

Joystick in direction	operation
	Backrest down AP 1 Tumbler filler
	LP (last position)

3.7 Multifunctional foot control

The foot-operated buttons on the multifunctional footswitch have two functions. The functions of the foot buttons depend on if an instrument is mounted or removed.

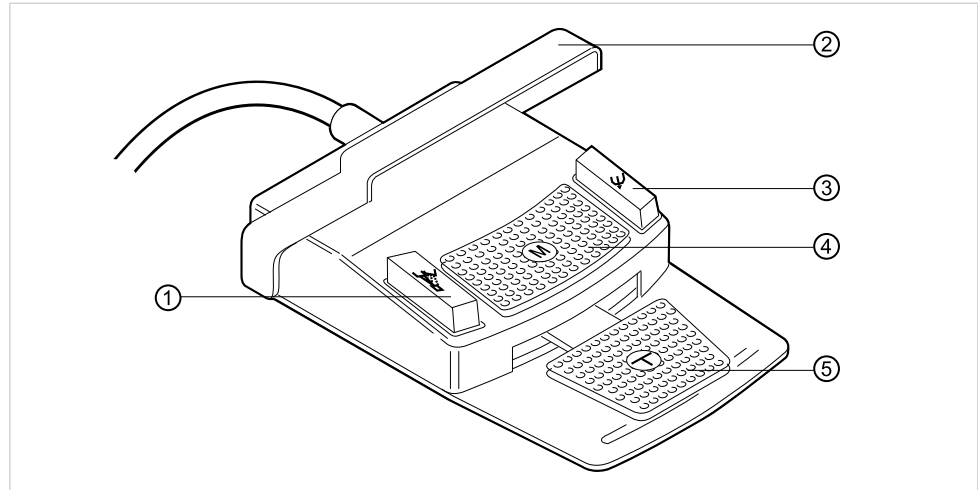

Item	Designation	Function with a mounted instrument	Function with a removed instrument
①	Spray preselection/AP footswitch	Moves the patient chair into automatic position.	Sets the preset spray.
②	Stirrup switch	Turns off the safety shutoff.	Switches the foot buttons to the "Chair movement" function
③	"Blown air/AP" footswitch	Moves the patient chair into automatic position.	Sets the preset blown air.
④	Cross-switch: "Counter-clockwise motor rotation"	Changes the position of the patient chair.	Selects the rotational direction of the motor (for the motor K200/KL 701/COMFORTdrive 200XD)
⑤	"Instruments" foot pedal	Generates a video freeze frame when the ER-GOcom is installed.	Starts the motor and controls the speed/intensity of the Instruments

3.8 Technical data

Drilling template and setup plan

Drilling template (Mat. no. 1.001.4755)	Right-handers (Rh): Page 001, Left-handers (LH): Page 002
With COMPACTchair (Mat. no. 1.003.6767)	Page 001 to 004
Setup plan (Mat. no. 1.001.4755)	Page 003 to 006 and 011 to 013
1058 TM	Rh: Page 003, Lh: Page 004
1058 S	Rh: Page 005, Lh: Page 006
1058 C	Rh: Page 011, Lh: Page 012
1058 G	Page 013
With COMPACTchair (Mat. no. 1.003.6767)	Page 005 to 008 and 013 to 015

Electrical system

Electrical lead	3 x 1.5 mm ²
Free end above the floor	1 000 mm
Input voltage	100/110/120/130/220/230/240 V AC
Frequency	50/60 Hz
Input voltage set by the manufacturer	See rating plate
Max. power consumption (including the KAVOLUX 1410) at 100 to 130 V	30 to 800 VA
Max. power consumption (including the KAVOLUX 1410) at 220 to 240 V	30 to 1,000 VA
Customer fuse protection	C16 m.c.b. or screw-plug fuse 10 A
Protective conductor above the floor	see DIN VDE 0100-710, 1000 mm
Heat emission at 100 to 130 V	162 to 1 675 KJ/h
Heat emission at 220 to 240 V	162 to 2 689 KJ/h
Mark of approval	CE / DVGW
Multifunctional foot control	IPX1 (moisture protection)

Water supply



Note

If the water is very hard (above 12 dH), a water softening device must be fitted in the ion-exchange process.

Insufficient water hardness (below 8.4 dH) can promote the formation of algae.

National water regulations apply to the compact water block kit. The following also applies: DIN EN 1717.

According to DIN EN 1717, each unit that is not listed by the DVGW in last the provided with an upstream type AA, AB or AD a safety device. (The DVGW water block kit and DVGW water bottle are certified; see the following list.)

When creating a water connection, prevent brackish water pools with standing water (also in the house plumbing).

You can find additional information at www.dvgw.de

Free drainage according to DVGW certificate DW-0402 BL 0465	DVGW water block, DVGW water bottle
Water quality	Tap water
Water hardness	1.5 - 2.14 mmol/l 8.4 - 12 dH
pH	7.2 to 7.8
Customer water filtration	80 µm
Water connection	R 1/2
Water connection above floor	min. 40 mm, max. 75 mm
Water inlet pressure	2.0 to 6.0 bar
Water outlet pressure	5 l/min
Diameter of the drain connection	40 mm
Drainage connection above floor	20 mm
Outflow quantity	max. 5 l/min
Slope of water drain pipe	From the unit, at least 10 mm per meter

Air supply

Air requirements according to DIN EN 7494-2	Dry, oil-free, dirt-free, non-contaminated
Air inlet pressure	5.2 bar to 7 bar
Air consumption	max. 80 NI/min.
Customer air filtration	50 µm
Air connection	R 1/2
Air connection above the floor	min. 40 mm, max. 75 mm
Diameter of the suction connection	40 mm
Suction connection above floor	20 mm
Suction vacuum	static at the device input: max. 180 mbar, dynamic: > 45 mbar, recommended: 60 mbar
Suction vacuum flow	500 NI/min.

The values apply to the KaVo measuring set (**Mat. no. 0.411.850**)

Operating environment

Floor quality	The quality of the floor must comply with the load bearing capacity for buildings DIN 1055 page 3 and the pressure resistance must correspond to DIN 18560 T 1.
Ambient temperature	+10 to +40°C

Relative humidity	30 to 75%
Air pressure	700 to 1,060 hPa

Transportation and storage conditions

Ambient temperature	-20 to +55°C
Relative humidity	5% to 95% non-condensing
Air pressure	700 to 1,060 hPa

Weight

Treatment unit with Standard patient chair	279 kg gross, 224 kg net
with steel setup plate and ERGOcom	344 kg gross, 289 kg net
Treatment unit with COMPACTchair	255 kg gross, 200 kg net
with steel setup plate and ERGOcom	320 kg gross, 265 kg net

For more information on the packages, see assembly instructions, section B 3

3.9 Rating plate and identification plate

Rating plate

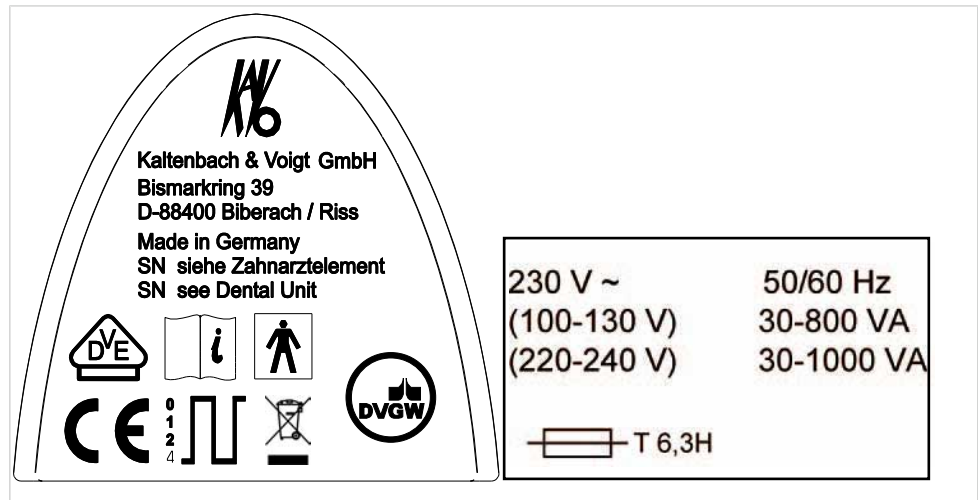

Rating plates inside and outside

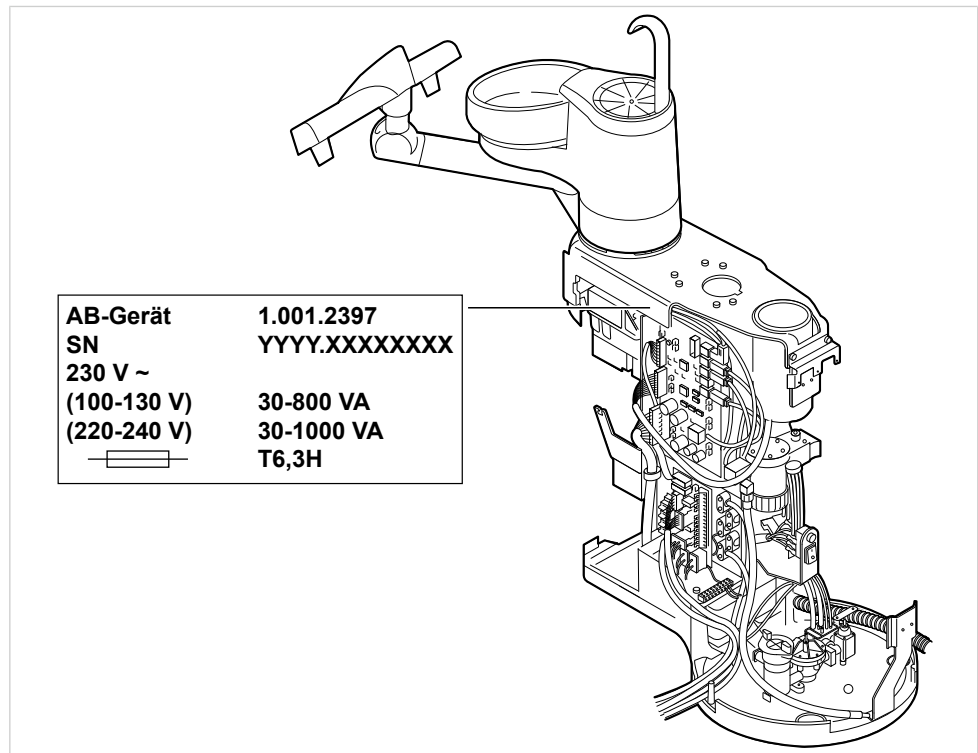

Inside attachment site for rating plate

3 Product description | 3.9 Rating plate and identification plate

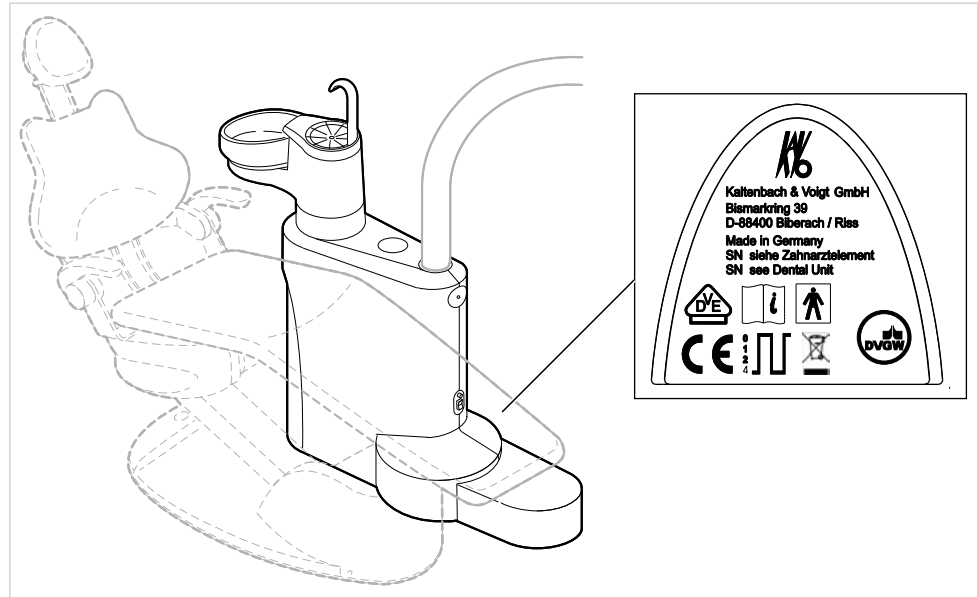

Outside attachment site for rating plate

SN	Serial number
	Please read and note the contents of the accompanying documents.
	Classification The handpieces are type BF application parts The patient chair is a type B application part
	Mode: Operating time for the patient chair: 25 seconds patient chair pause time: 400 seconds (The permissible operating times correspond to dental practice).
	Disposal instructions, see also: Purpose - proper use
	CE mark according to EC Directive 93/42 for medical devices
	VDE mark
	DVGW ID (Deutscher Verein des Gas- und Wasserfaches e.V.)

Identification plates



Identification plate example 1058 S

Type	Device type
SN	Year of manufacture - serial number
REF	Material number

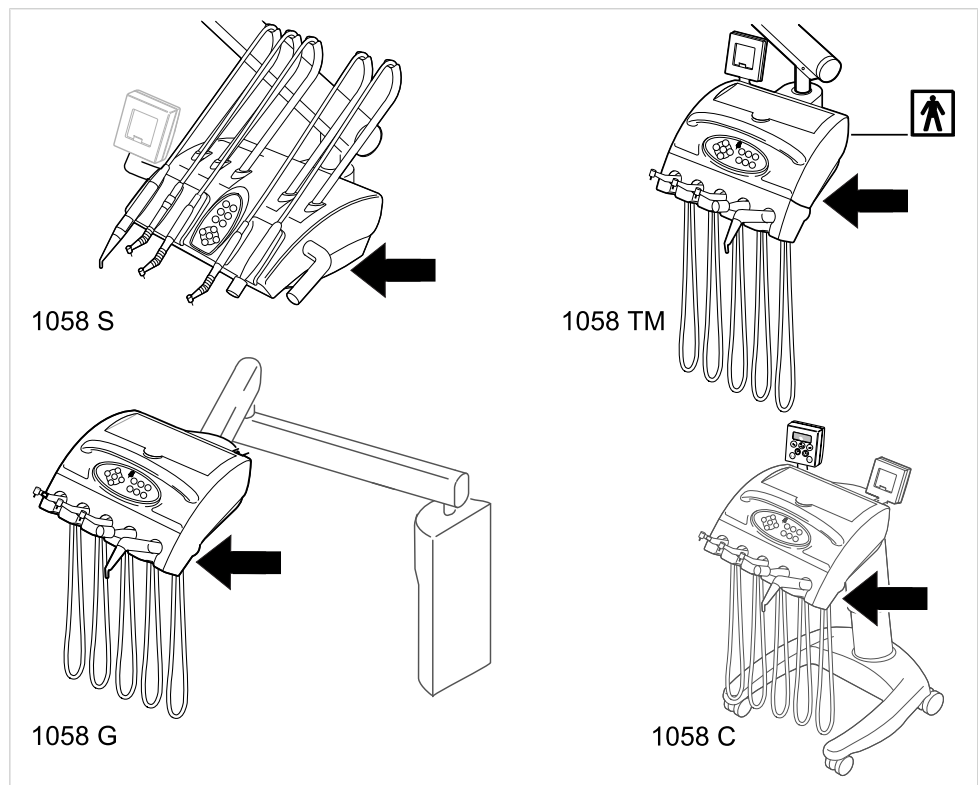

Attachment locations for identification plates

4 Operation

4.1 Turn the unit on and off

The main switch has the following tasks:

- It must be possible to plug in or disconnect all the pins of the unit's plug into the customer's power supply.
- The customer's compressed air and water supplies are connected and disconnected using the solenoid valves and compressed air control installed in the device.

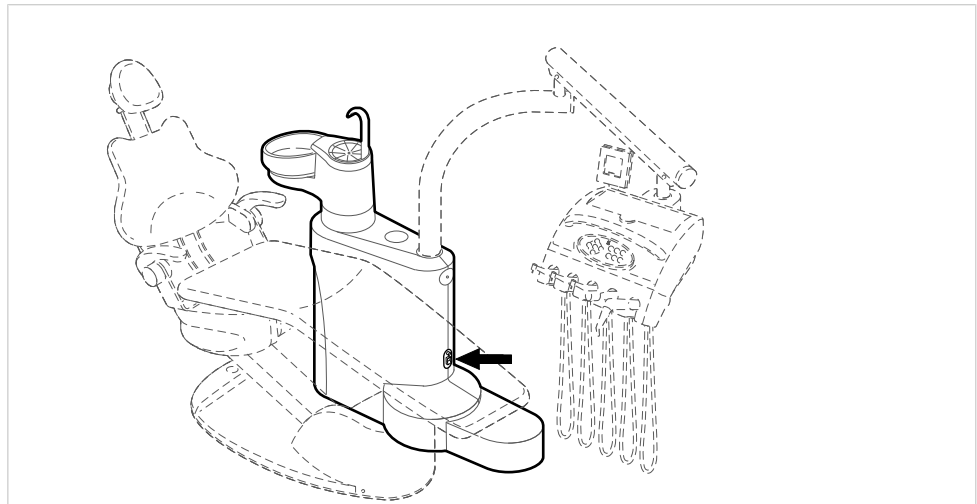

- ▶ Turn on the machine with the main switch.
When the unit is ready to operate, the green LED ① shines (memory level Dentist 1) or the yellow LED ② (memory level Dentist 2).
The operability is not displayed on the standard assistant unit.

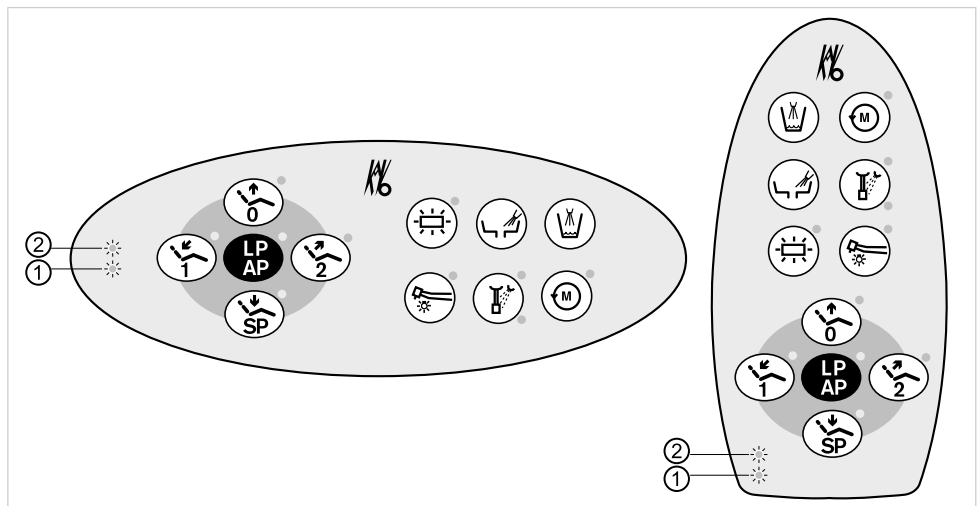

Note

To prevent water damage, the main switch must be turned off before leaving the dental practice.

4.2 Adjusting the patient chair

4.2.1 Adjust the arm rest

Arm rest for the standard patient chair

To make it easier for the patient to sit in the chair, the armrest can be swung up.



The patient's hands are in a bad position when the chair is rising
Danger of crushing fingers between the backrest and armrest.
► Make sure that the patient is sitting in the right position (especially children).

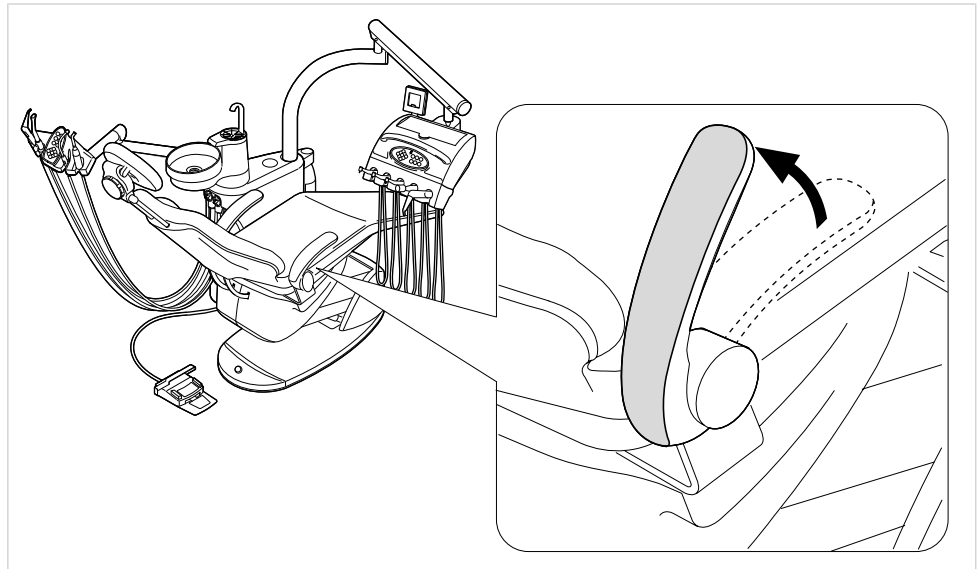

Armrest for the COMPACTchair patient chair (extra)

To make it easier for the patient to sit in the chair, the armrest can be swung out.

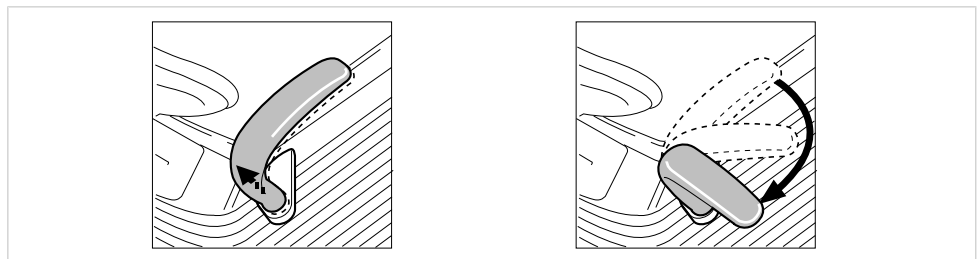

- Pull the arm rest up and swing it out.
- Then swing the armrest back until it locks in place.

To prevent the armrest from swinging out unintentionally, it can be fixed in place.



Note

The armrest on the side of the device body must be fixed to prevent collisions.

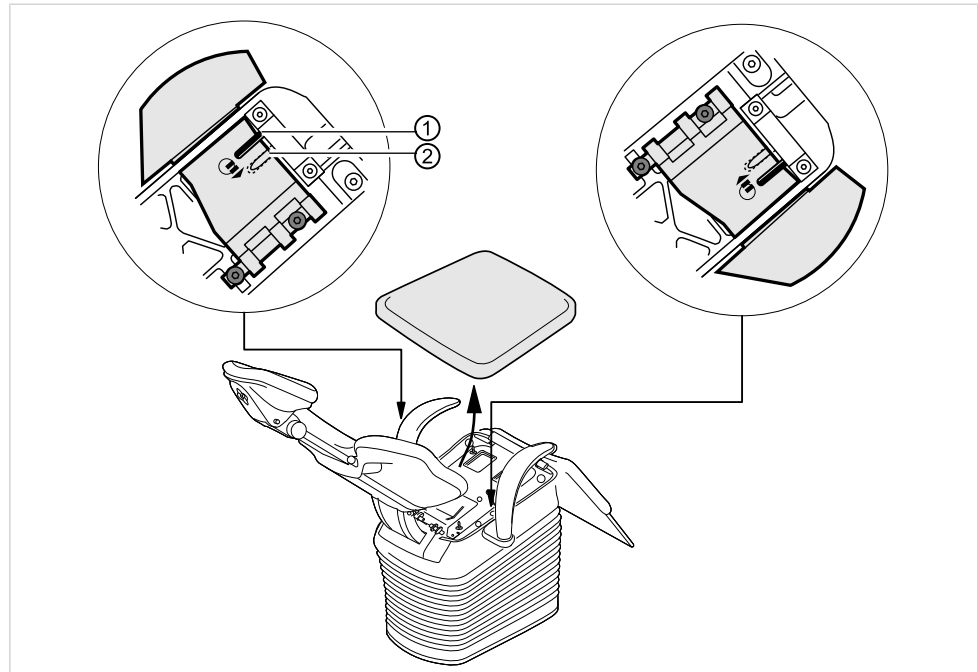

- ▶ Release the clips and remove the seat cushion.
- ▶ Move the safety lever into position ① to fix the armrest.
- ▶ Move the safety lever into position ② to allow the armrest to swing.

4.2.2 Adjust the seat

The seat can be tipped into four different positions to provide a lying surface for treating the maxilla for children of different sizes.

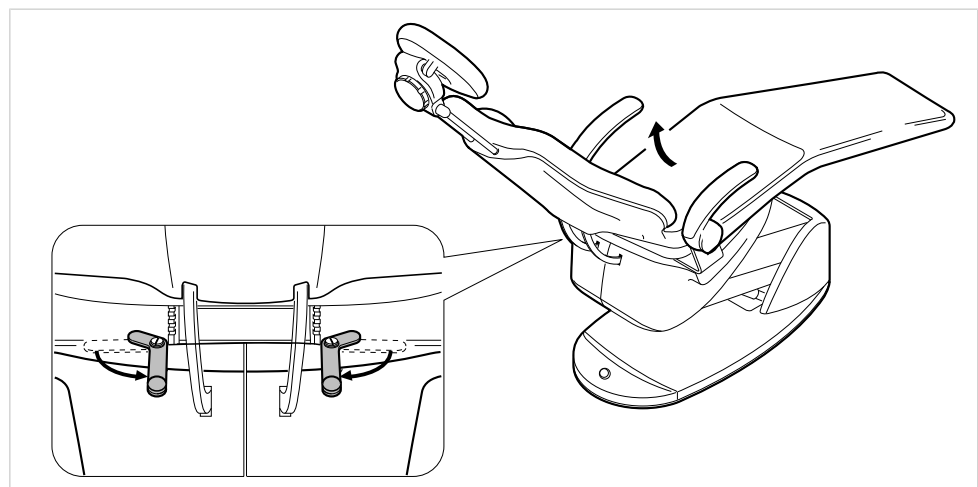

- ▶ Release the lock lever and tip the seat into the required position.

- ▶ Make sure that the lock lever fully locks into place.

4.2.3 Adjust head rest

Adjust the headrest for the standard patient chair



Adjusting the headrest

Injury to the neck muscles

- ▶ Make sure that the patient is aware of the headrest setting.
- ▶ Patients need to raise their head slightly during adjustment.

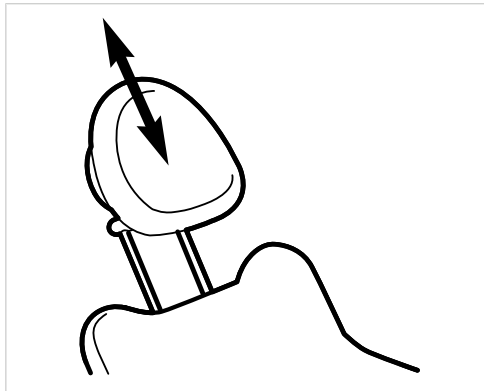

- ▶ Push in or pull out the headrest depending on the patient's size.

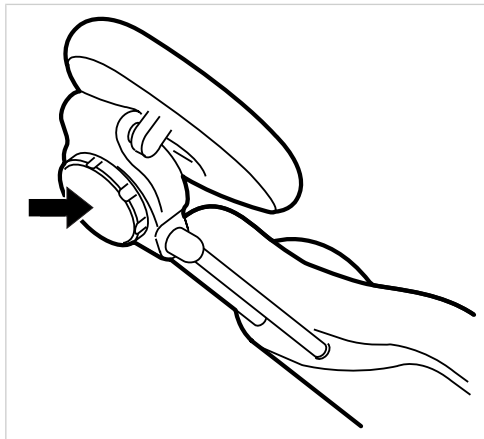

- ▶ To swing the headrest, turn the locking dial to the left, move the headrest into position, and turn the dial to the right to lock it.

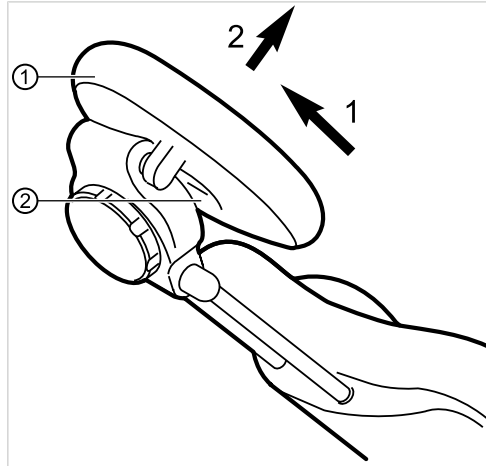

- ▶ To remove the headrest cushion, remove the screw ②, pull the cushion ① up slightly, and remove it to the front.

Adjust the headrest for the COMPACTchair patient chair



Adjusting the headrest

Injury to the neck muscles

- ▶ Make sure that the patient is aware of the headrest setting.
- ▶ Patients need to raise their head slightly during adjustment.

The bar length and angle of the headrest can be adjusted.

- ▶ Press the lock button and push in or pull out the headrest depending on the patient's height.



Note

The service technician can adjust the braking force.

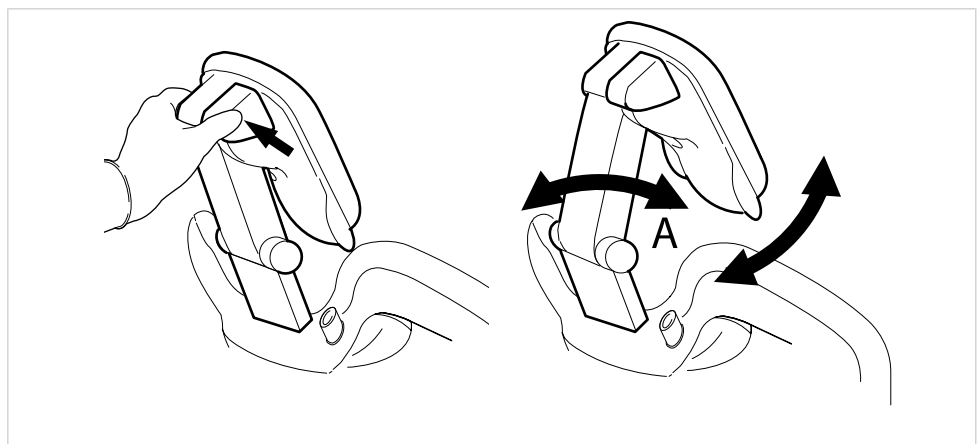

- ▶ Press the lock button and swing the headrest into the desired position.
When swinging the headrest back into position, make sure that there is nothing between the area A and head cushion.

Turning the head cushion

The head rest cushion is a rotating cushion. It can be turned to offer better neck support, for example when treating children.

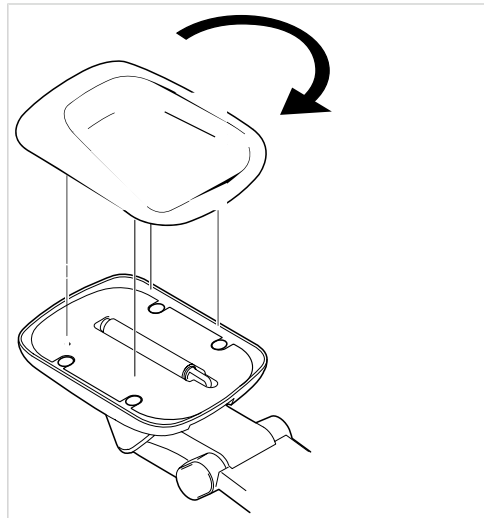

- ▶ Evenly pull the cushion up and rotate it 180°.
- ▶ Then snap the head cushion back on.

Adjust the headrest with the help of the motor

The motor for the headrest allows you to position the patient with easy manoeuvres. The compensated sequence of movements move the patient's head into an anatomically correct position.

The height and angle of the headrest can be adjusted with the soft silicone joystick switch ①.

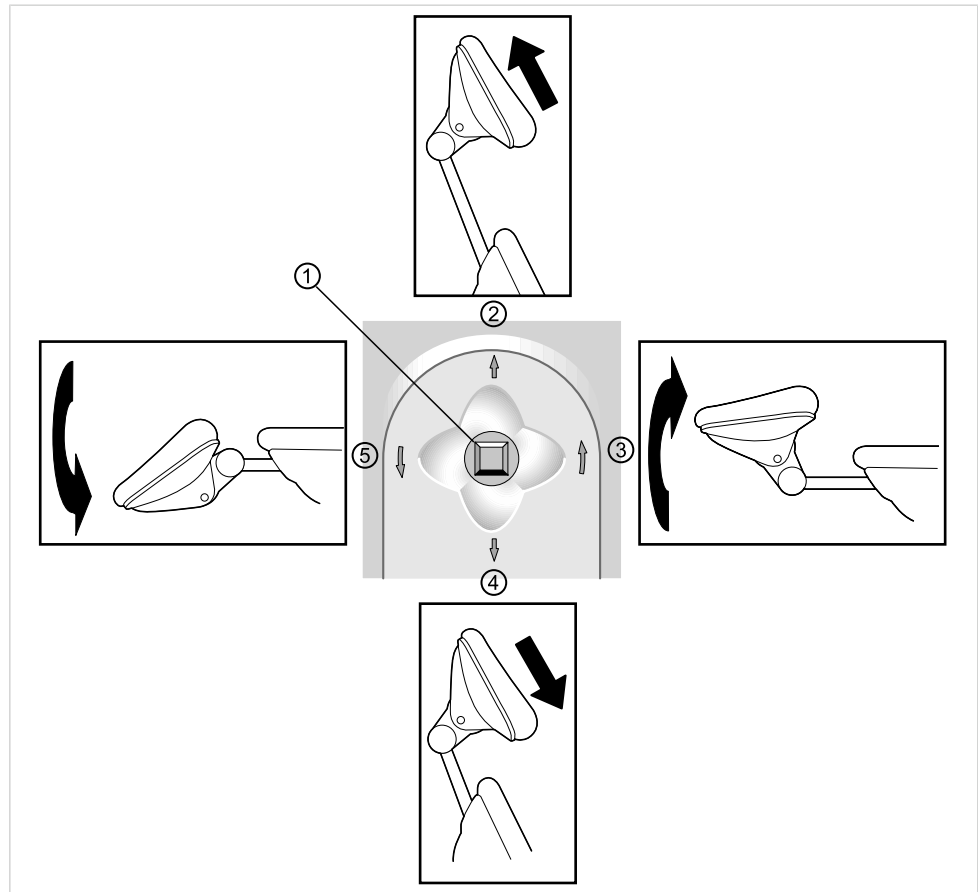

- ▶ Press the joystick switch ① in direction ② to extend the bar length.
- ▶ Move the joystick switch ① in direction ④ to shorten the bar length.
- ▶ Press the joystick switch ① in direction ③ to angle the headrest the the front, for example for treating the maxilla (compensated procedure).
- ▶ Press the joystick switch ① in direction ⑤ to angle the headrest the the rear, for example for treating the mandible (compensated procedure).

Special function 1 (small persons, round shoulders):

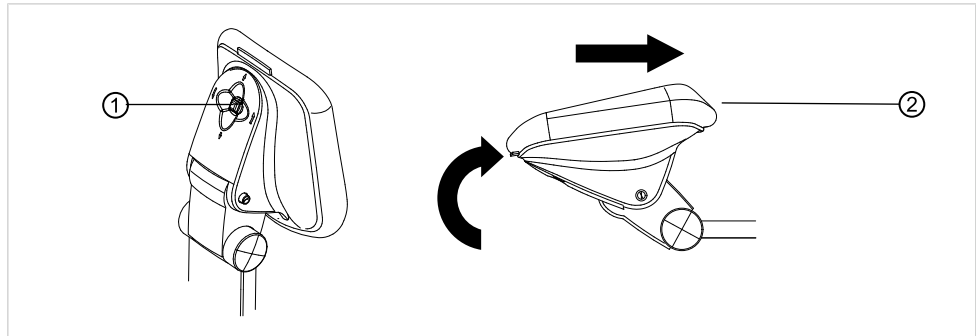

- ▶ Press joystick switch ①. signal sounds. Compensation is turned off. All six of the AP display diodes shine. All axes can be independently operated using the joystick switch ①.
- ▶ Position the headrest ② with the joystick ①.

Press the joystick switch ① again to move to the standard initial position. All functions are available.

Special function 2 (children's position, continuous plane):

For treating children, the head cushion can be adjusted so that it forms a single plane with the backrest cushion.

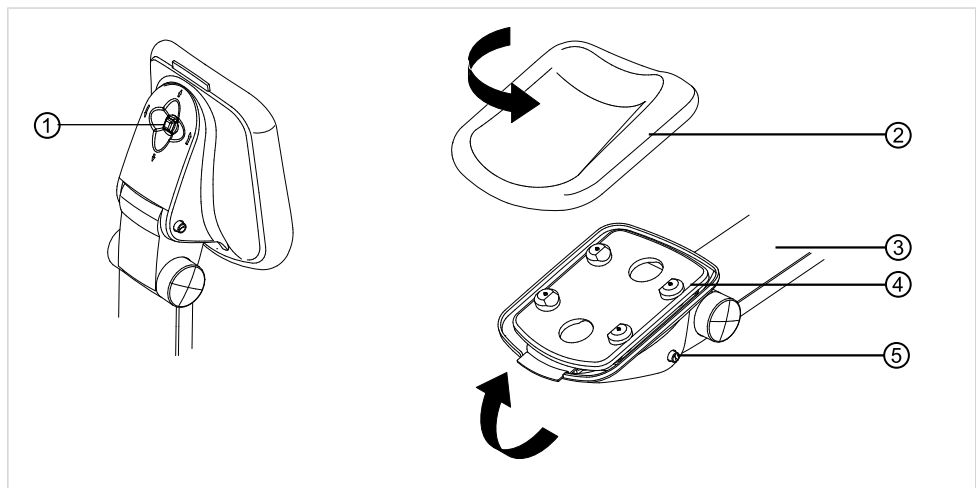

Note

When press button ⑤, do not adjust the angle with the joystick switch ①!

- ▶ Press joystick switch ① twice. signal sounds. The programmed position for treating children is assumed (bar is completely inserted ③). The child's position is displayed by the running light of the six AP keys.

- ▶ Press button ⑤ to move jammed headrests ④.
- ▶ Tip the headrest ④ until it is in line with the backrest and locks into place.
- ▶ If necessary, change the bar length ③.
- ▶ Turn the rotating cushion ② so that the flat part faces the backrest.

Press button ① and manually swing the headrest back to automatically assume the standard starting position. All functions are again available.

4.2.4 Adjust chair position

The chair position can be gradually adjusted.

The chair positions can be saved, and the saved positions can be retrieved by the push of a button.

The chair and backrest movements are simultaneous in the automatic program. Exception: When the operating voltage for the standard patient chair is below 200 V, the movements in the automatic program are sequential. In this case, a service technician must change the program.

Automatic chair motor shutoff

The chair motors automatically shut off when they reach an operating temperature of 140°C. This high temperature is only reached when they are frequently actuated, e.g. in demonstrations. This temperature is never reached in normal work. After the motors automatically shut off, they will be operable again after about 15 minutes.

Gradually adjust the chair position

The standard patient chair and COMPACTchair are adjusted in the same manner.









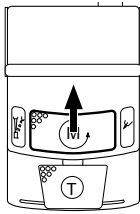

Note

The functions of the control keys on the dentist unit and assistant unit are the same.

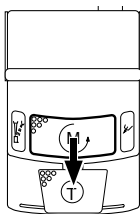
The chair position can be selectively adjusted with:

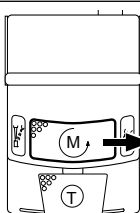
- Keys on the control unit
- Joystick on the standard assistant unit
- Cross switch on the foot control

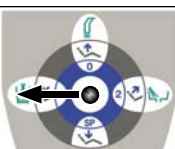
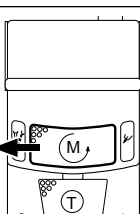
Dentist unit key	Joystick for the standard assistant unit	Cross-switch: "Counterclockwise motor rotation"	operation
			The seat moves upward.
			The seat moves down.
			The backrest moves upward.
			The backrest moves downward.

- ▶ Press the desired button, or press the joystick or cross switch in the desired direction.

The seat/backrest moves in the desired direction.



Note

If an instrument is removed, the chair functions of the multifunctional foot control are blocked. The blocking can be removed by briefly pressing the stirrup switch. The functions are then available.



Note

The seat and backrest can be moved at the same time. Exception: When the operating voltage of the standard patient chair is below 200 V, only sequential movements are possible.

Special features of the COMPACTchair



Note

If the backrest is moved, the foldable foot piece also moves. The foot section cannot be moved separately.

The backrest can be moved vertically up to 85° to make it easier for patients to get in and out.

When the backrest is horizontal, the chair can be moved lower than when the backrest is vertical.

Save chair positions

The chair positions can be saved and retrieved at any time by the press of a button. When the position is retrieved, the chair automatically moves to the saved position (the so-called "automatic position," or "AP" for short).

The four chair positions can be saved on the control panels. Two positions can be additionally saved with the multifunctional foot control.

It is for example recommendable to save the sitting down/getting up position using the "AP 0" key, and the rising position with the "SP" key.

- ▶ Move the chair into the position that is to be saved.

See also: 4.2.4 Gradually adjust the chair position, Page 41

Save on the Comfort dentist or assistant unit

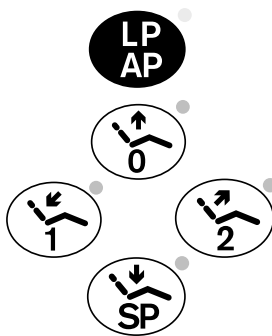

- ▶ Briefly press the LP/AP button.
The LEDs of the buttons "AP 0", "AP 1", "AP 2" and "SP" flash for about four seconds.
- ▶ During these four seconds, press the "AP 0", "AP 1", "AP 2" or "SP" buttons until you hear a beep.
The chair position is saved on the button.



Note

The automatic position "Last position" is saved on the "LP" button. Press the "LP" button for the chair to automatically move to the last position before the rinsing position. The "LP" button cannot be saved with another automatic position.

Save with the foot control

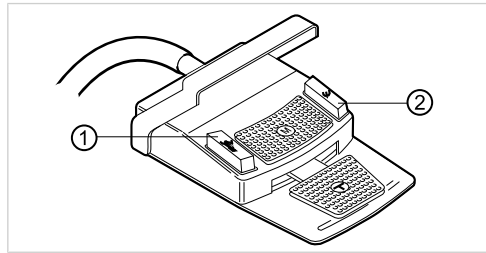

① Spray preselection/AP footswitch

② Blown air/AP footswitch

The chair positions can be saved on two footswitches; the standard setting is as follows:

- "Preselected spray" footswitch: "LP" automatic position (last position)
- "Blown air" footswitch: "SP" automatic position (rinsing position)

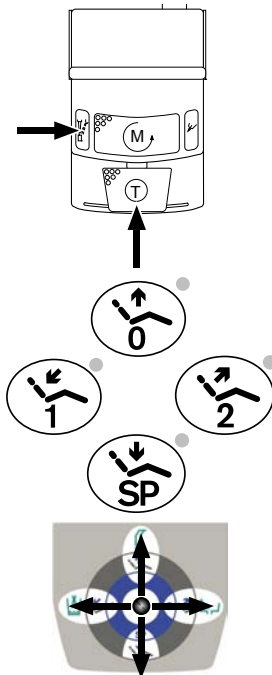

- ▶ Simultaneously press the foot pedal and the "Preselected spray" or "Blown air" foot switch.

- ▶ Press the "AP 0", "AP 1", "AP 2" or "SP" buttons on the control element until you hear a beep.

or

- ▶ Move the joystick on the standard assistant unit in the direction of the desired automatic position until you hear a beep.

The selected automatic position is saved on the footswitch.

Retrieve saved chair positions

The saved positions of the chair (so-called automatic positions) can be retrieved with the press of a button and the joystick. Five automatic positions can be retrieved with the dentist unit and assistant unit, and two automatic positions can be retrieved with the multi-functional foot control.

See also: 4.2.4 Save chair positions, Page 43



Danger of crushing during automatic chair movement

The patient or treatment personnel can be clamped.

- ▶ Monitor the patient and treatment personnel when changing the chair position.

Retrieve the chair positions using the control element

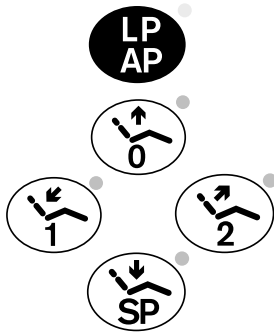

- ▶ Briefly press the LP/AP button.
The LEDs of the buttons "AP 0", " AP 1", " AP 2" and "SP" flash for about four seconds.
- ▶ During these four seconds, briefly press the "AP 0", " AP 1", " AP 2" or "SP" buttons.
The chair moves into the automatic position.

Retrieve the chair positions using the standard assistant unit



- ▶ Briefly press the joystick.
The LEDs of the buttons "AP 0", " AP 1", " AP 2" and "SP" flash for about four seconds on the dentist unit.
- ▶ To move the chair into the last position before the rinsing position, press the joystick during this period of four seconds.
- ▶ To move the chair into a different position, move the joystick in the direction of the desired automatic position during this period of four seconds.

The chair moves into the automatic position.

Retrieve the chair positions using the multifunctional foot control



Note

If an instrument is removed, the chair functions of the multifunctional foot control are blocked. The blocking can be removed by briefly pressing the stirrup switch. The functions are then available.

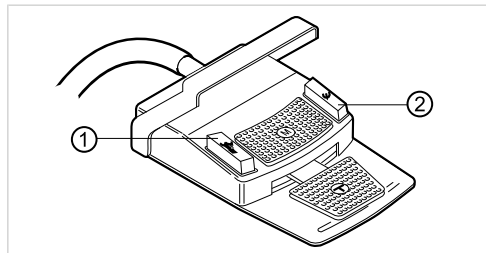

① Spray preselection/AP footswitch ② Blown air/AP footswitch

The chair positions can be retrieved with two footswitches; the standard setting is as follows:

- "Preselected spray" footswitch: "LP" automatic position (last position)
- "Blown air" footswitch: "SP" automatic position (rinsing position)

Move the chair when the instrument is mounted

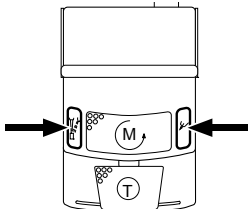

- ▶ Press the "Preselected spray" or "Blown air" foot switch.

The chair moves into the automatic position.

Move the chair when the instrument is mounted



Note

If an instrument is removed, the chair functions of the multifunctional foot control are blocked. The blocking can be removed by briefly pressing the stirrup switch. The functions are then available.

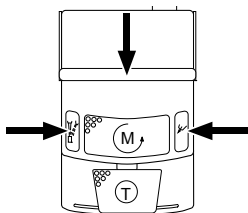

- ▶ Press the stirrup switch and then the "Preselected spray" or "Blown air" foot switch.

The chair moves into the automatic position.

4.2.5 Safety shut-off

To prevent collisions arising from the movement of the patient chair, safety shutoff switches are installed to protect the patient and practice personnel from injury and the treatment unit from damage.



CAUTION

Despite the safety shutoffs, collisions with the patient chair can occur in certain positions of the assistant unit.

Damage to the assistant element and patient chair

- ▶ Keep the assistant unit out of the range of movement of the patient chair.
- ▶ Always monitor the chair movement.



CAUTION

Pinching from the treatment chair

The safety shutoff of the treatment chair is activated by lifting the respective component. Depending on the patient's body weight and the leverage, more force can be exerted on the object to be triggered than is necessary to trigger the switching function.

- ▶ The treatment personnel must move outside of the chair's swinging range whenever the chair moves.

The safety cut-offs can be found at the following places on the treatment unit.

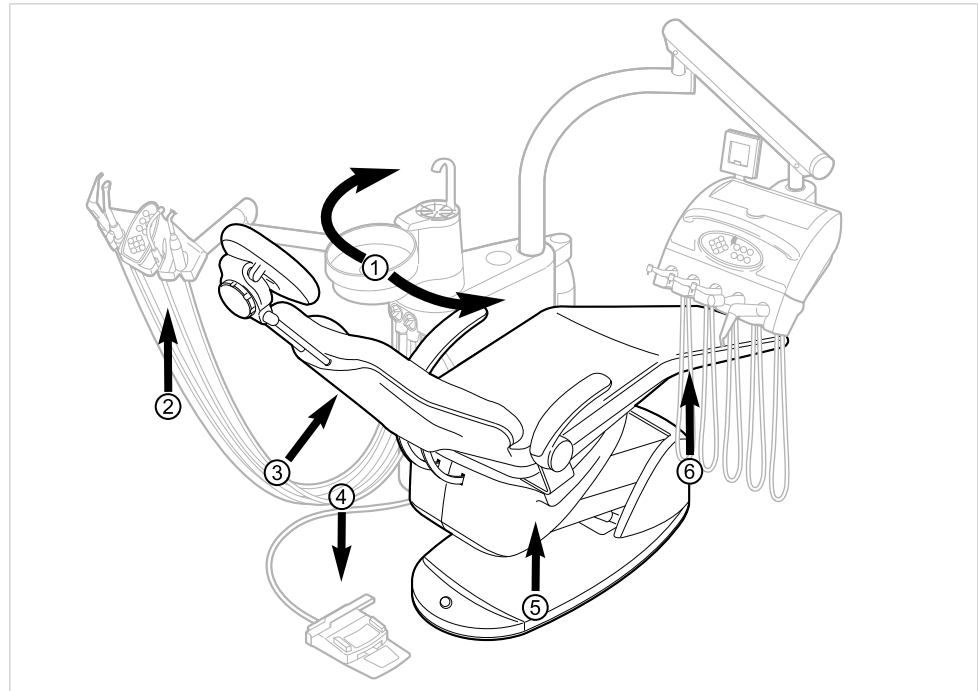

Safety shutoff for the standard patient chair

- | | |
|---|---|
| ① Patient unit swung over the patient chair | ④ Stirrup on multifunctional foot control |
| ② Assistant unit | ⑤ Bottom of the chair parallelogram |
| ③ Backrest | ⑥ Seat |

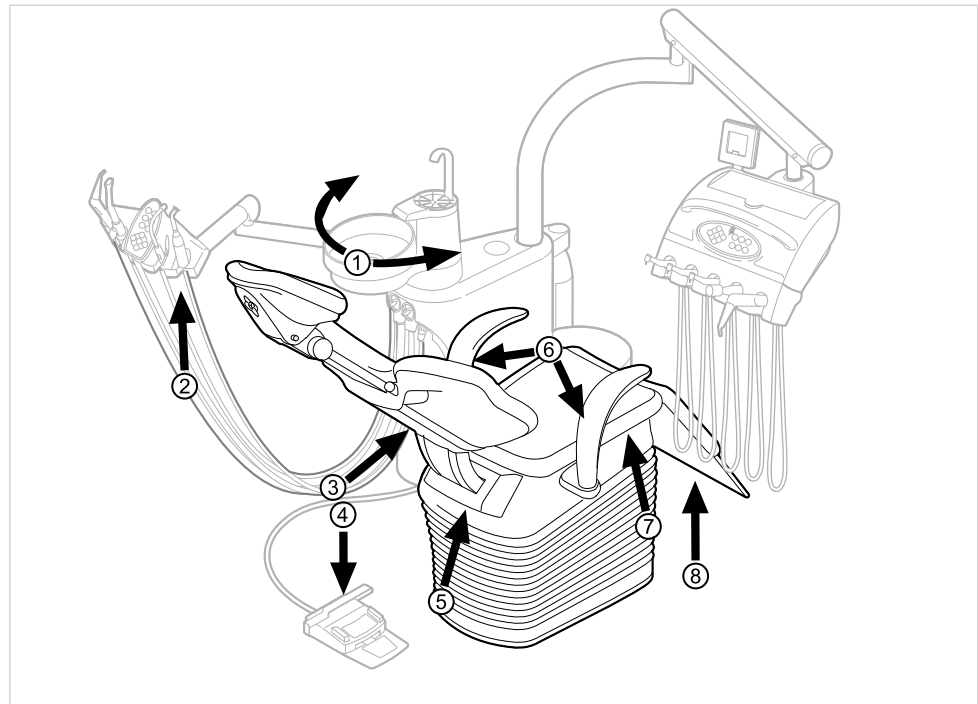





Safety shutoff for the COMPACTchair patient chair

- | | |
|---|---|
| ① Patient unit swung over the patient chair | ⑤ Cover on the curved segment of the backrest |
| ② Assistant unit | ⑥ Arm rests |
| ③ Backrest | ⑦ Seat |
| ④ Stirrup on the foot control | ⑧ Foldable part of the seat |

The safety shutoff occurs when a movement angle has been exceeded, or part of the treatment unit collides with an object.

If a person or object actuates a safety shutoff, the chair immediately stops moving. The fact that the safety shutoff has been activated is displayed by the corresponding display flashing on the dentist's or assistant's unit.

Display LED	Safety shut-off
	Assistant unit
	Backrest Arm rests
	Multifunctional foot control
	Patient unit
	Patient unit



Note

The chair's position cannot be changed with the key wheels when a safety shutoff is activated.

Exception: The patient unit safety switch only stops the upward and downward movement of the patient chair. The backrest can be moved up and down.

4.3 Move the dentist's unit

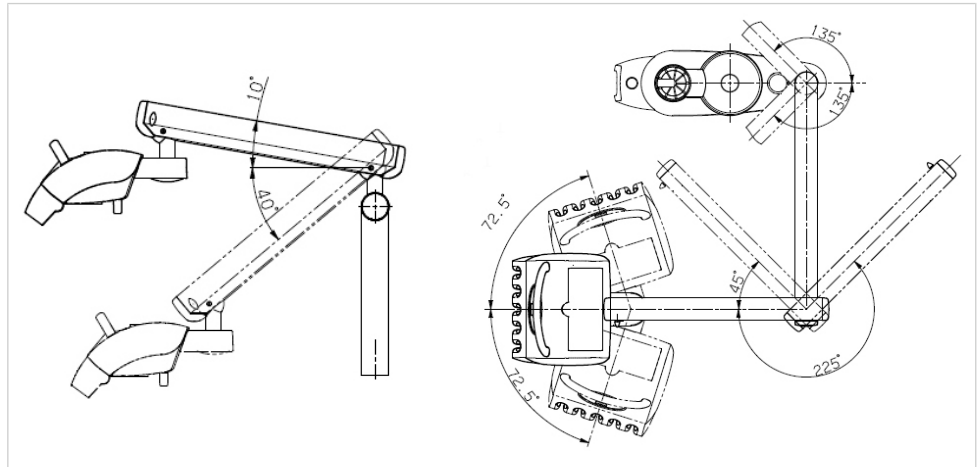

dentist unit TM

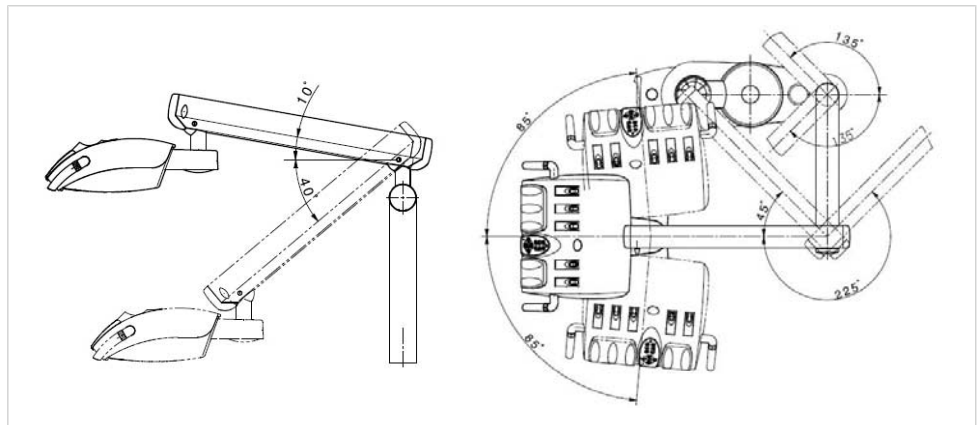

Dentist unit S

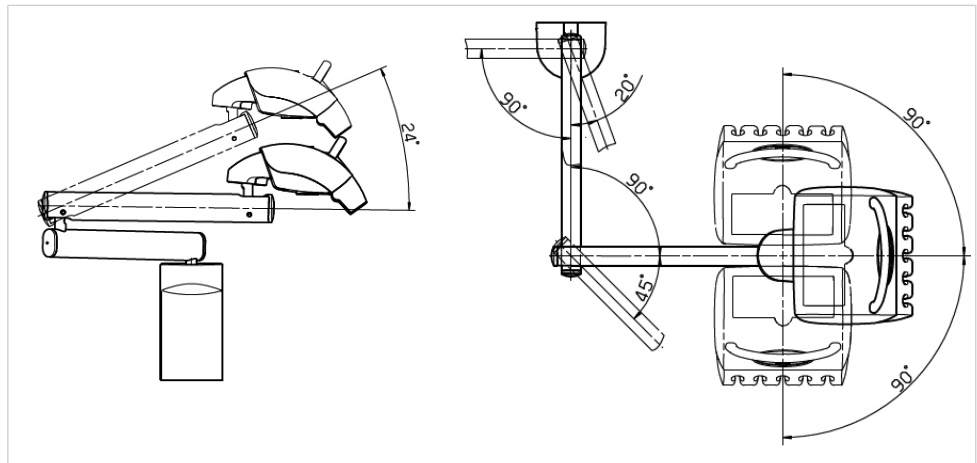

Dentist unit G

The swinging range of the dentist unit is limited by stops.



Note

Do not pull the dentist unit by the instrument hose.

- ▶ To adjust the dentist unit height, release the brake, adjust the height, and reset the brake.

4.3.1 Move the cart



CAUTION

Moving and overloading the cart.

Danger of tipping and damaging the cart.

- ▶ Only use the card on a continuously smooth floor.
- ▶ Do not overextend the supply hose for the cart.
- ▶ Make sure that there are no obstructions on the floor.
- ▶ Do not sit on the provider part or step on the castor.



Note

The area in which the cart can be move is restricted by the length of the lines and hoses that connect the cart to the base of the device. Only move the cart within this range.

- ▶ To change the position of the cart, hold the cart by the bow-type handle and move it to the desired position. Make sure that there are no obstructions on the floor.

The top part of the dentist's unit can be positioned in 9 levels.



Note

Do not lift the dentist's unit using the handle. The handle is only for horizontally positioning the dentist unit.

4 Operation | 4.3 Move the dentist's unit

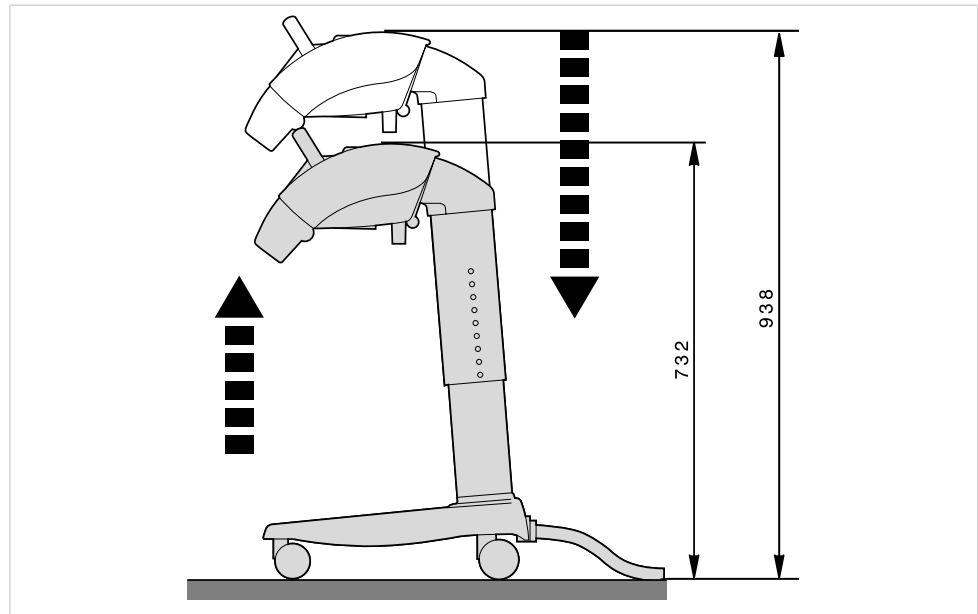

- ▶ Lift the top part of the dentist's unit until it locks into place.
- ▶ To release the lock, move the top part all the way up and then move it down.

4.4 Move the patient unit

4.4.1 Swing the patient unit by hand

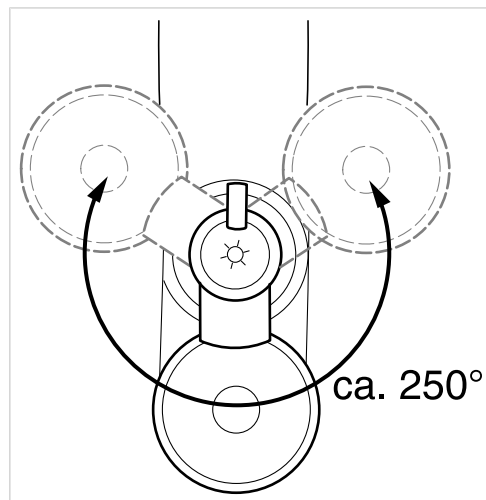

The swinging range is about 250°C.



Note

When the patient unit is swung over the patient chair, the safety shutoff is activated.

4.5 Adjust the height of the assistant unit

The dentist unit can be vertically positioned in four levels.

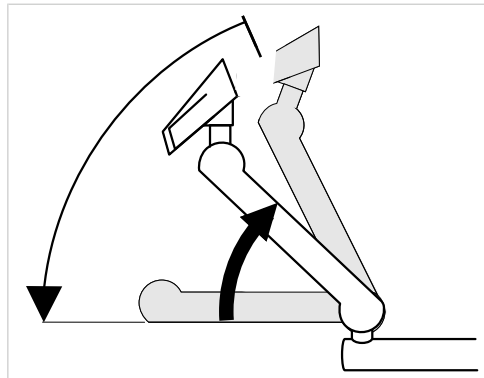

- ▶ To set a higher level, pull the assistant unit upward gently until it audibly locks in place.
- ▶ To set a lower level, pull the assistant unit all the way up until the lock releases, and then lower the assistant unit.

4.6 Setting functions

4.6.1 Select memory level Dentist 1 or Dentist 2



Note

To individually adjust instruments for different types of treatment, two dentist levels can be selected.

- ▶ Set down the instruments.
 - ▶ Hold down the foot pedal and press the stirrup switch.
- or
- ▶ With the Memospeed (extra), press the "Preselect level" button until you hear a signal.

Green LED comes on: Dentist level 1 is selected.
 Yellow LED comes on: Dentist level 2 is selected.

4.6.2 Fill the tumbler and rinse the spittoon

The operation of the tumbler filler and bowl rising is the same for the Comfort dentist unit and assistant unit.

All steps can also be performed with the joystick on the standard assistant unit.
 The time for filling the tumbler and rinsing the bowl can be adjusted.

Adjust at the time for bowl rinsing and tumbler filling

Beeps sound when adjusting the time. Each beep corresponds to one second. The maximum time is 51 seconds.



- ▶ Press the button for filling the tumbler or rinsing the bowl and hold it until the desired number of beeps have sounded.

Adjusting the time on the standard assistant unit

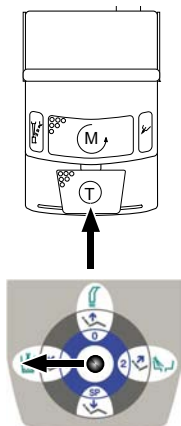

- ▶ Press and hold down the foot pedal.
- ▶ To adjust time for filling the tumbler, move the joystick to the left and hold it until the desired number of beeps sound.

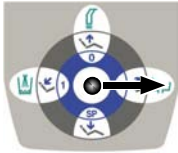

- ▶ To adjust time for rinsing the bowl, move the joystick to the right and hold it until the desired number of beeps sound.

Filling the tumbler



- ▶ Press the "Tumbler filler" button.

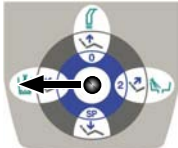

or

- ▶ Briefly move the joystick on the standard assistant unit to the left.

The tumbler is filled.

- ▶ To stop filling before the set time, press the "Tumbler filler" button again.

Rinsing the spittoon



Note

Do not pour any liquid into the spittoon when the device is turned off.



- ▶ Press the "Spittoon" button.



or

- ▶ Briefly move the joystick on the standard assistant unit to the right.

The spittoon is rinsed.

- ▶ To stop rinsing before the set time, press the "Spittoon" button or move the joystick again.

4.6.3 Turn the x-ray image viewer on and off



- ▶ Press the "X-ray viewer" button.

4.6.4 Turn the treatment light on and off using the cold light button

The KAVOSUN 1415 and KAVOLUX 1410 treatment light can be turned on and off using the cold light button when a corresponding setting is made in service mode (group 9) and when a DCA relay is installed.



- ▶ Set down all the instruments.
- ▶ Press the "Cold light" button to turn the treatment light on or off.

4.6.5 Set the time and use the timer (only with Memospeed)

Adjusting the clock time

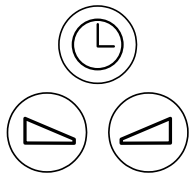

- ▶ Press the "Clock" button until you hear a beep.
- ▶ Press the "Increase value" or "Decrease value" button until the desired number of hours is displayed.
- ▶ Briefly press the "Clock" button, and set the minutes by pressing the "Reduce value" and "Increase value" buttons.
- ▶ Press the "Clock" button again to set the seconds in the same manner.
- ▶ Then press the "Clock" button until you hear a beep.
The time is now saved.

Setting the timer

The minimum timer time is 30 seconds, and the maximum timer time is 8 minutes.

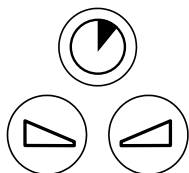

- ▶ Press the "Timer" button until you hear a beep.
- ▶ Press the "Increase value" or "Decrease value" button until the desired timer time is displayed.
- ▶ Press the "Timer" button again until you hear a beep.
The timer time is now saved.

Starting the timer



- ▶ Press the "Timer" button.

The set timer time runs. A tone sounds after the timer time is over.

4.6.6 Using the function keys

From the 14 functions, you can select two that can be retrieved using the function keys.

Select and save the function

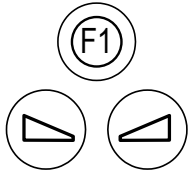

- ▶ Press "F1" or "F2" until you hear a tone.
The programming mode is started.
- ▶ Press the "Increase value" or "Decrease value" button until the desired function is displayed.
- ▶ Press the "F1" or "F2" button again until you hear a tone.
The function is saved on the button.

Calling up a function

Requirement

A function has been saved for the "F1" or "F2" key.



- ▶ Briefly press the "F1" or "F2" button.
These saved function is triggered.

4.7 Using instruments

The following sections describe the use and setting of the instruments. A distinction is drawn between operation with and without the installed Memospeed. The instruments are prevented from simultaneous use by software that determines when they are mounted. To make use easier, specific instrument settings can be saved.

Holder logic

Only the instrument that was first removed is operable with the exception of the triple function handpiece. All other instruments do not work; the drill bits or PIEZOlux tips of these instruments can be changed.

4.7.1 Save instrument-specific settings

The following settings can be individually saved for the instruments:

Instrument	Setting
Turbine	cold light intensity Spray on/off
INTRA LUX Motor KL 701 / K 200 COMFORTdrive	cold light intensity Spray on/off Speed range and intensity Direction of rotation
PIEZOlux	cold light intensity Spray on/off* Intensity
Multifunctional handpiece	Cold light and heating On/off

*Only with a corresponding setting in service mode, group 9.



- ▶ To save a set value without the Memospeed, press the "LP/AP" button when the instrument is removed until you hear a beep.



- ▶ To save a set value with the Memospeed, press the "Preselect level" button when the instrument is removed until you hear a beep.



Note

Changed values are lost when the changes are not saved before the unit is turned off.

Select a memory level when the Memospeed is mounted



- ▶ Press the "Preselect level" several times until the desired level is displayed.

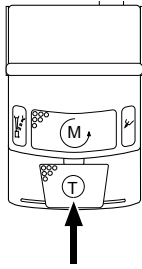

or

- ▶ Press the foot pedal several times when the instrument is mounted until the desired level is displayed.

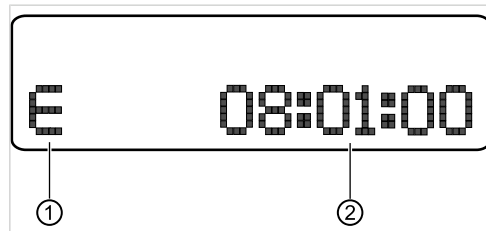

Memospeed Display

① Level display

② Time

4.7.2 Using the turbine



Note

Follow the instructions for use and assembly in the instrument packaging.

The following settings can be changed:

- Speed
- Preset spray
- Cold light preselection and intensity

Adjust the turbine without Memospeed

- ▶ Remove the turbine from the holder.

Setting the speed

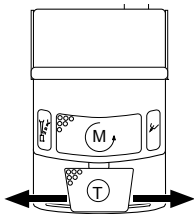

- ▶ To reduce or increase the speed, move the foot pedal to the left or right.



Note

The speed cannot be stored.

The minimum and maximum speed depends upon the type of used turbine.

Setting the cooling condition

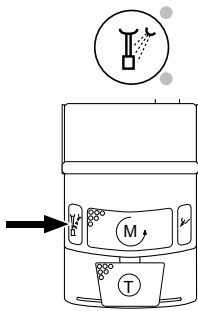

- ▶ Press the "Preselected spray" button.

or

- ▶ "Preselected spray" footswitch.

Two LEDs shine when the spray cooling level is activated.

Setting cold light intensity



- ▶ To preset the cold light, press the "Cold light" button. The LED shines at the preset cold light.

The cold light intensity can be set in 10 levels. When you are setting the intensity, the intensity is signalled by the number of beeps ranging from one beep (minimum intensity) to 10 beeps (maximum intensity).



- ▶ To set the cold light intensity, press the "Cold light" button until you hear the desired number of beeps.

Storing values



- ▶ Press the "LP/AP" button until you hear a beep.

Adjust the turbine with Memospeed

The spray preset is selected in the same way as without the Memospeed.

- ▶ Remove the turbine from the holder.
- ▶ Setting the level.

See also: 4.7.1 Select a memory level when the Memospeed is mounted, Page 60

Setting the speed



Note

The speed can be set at level E only with the foot pedal.

Two modes are available:

- "Manual" mode: These speed can be adjusted gradually using the foot pedal.

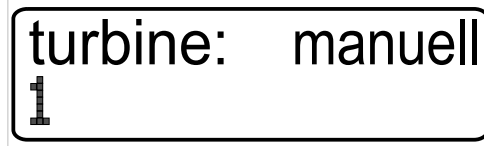

- "Maximum" mode: The speed remains at the maximum level independent of the foot pedal setting.

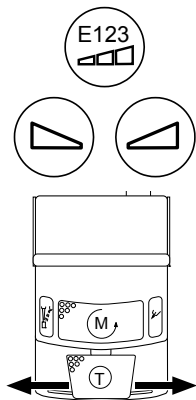

- ▶ Press the "Level selection" button until you hear a beep.
- ▶ To switch between maximum and minimum mode, press the "Increase value" or "Reduce value" button.
- ▶ To reduce or increase the speed in manual mode, move the foot pedal to the left or right.

Setting cold light intensity

The cold light intensity can be set in 10 levels.

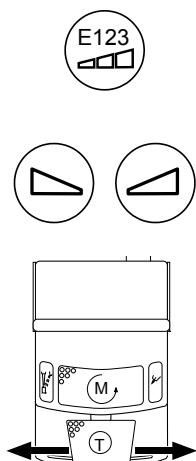

- ▶ Press the "Level selection" button.
- ▶ Set the desired intensity from 1 to 10 by pressing the "Reduce value" or "Increase value" buttons, or by moving the foot pedal to the left or right.

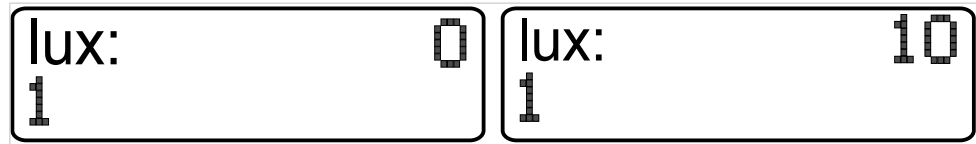

Storing values



- ▶ Press the "Level selection" button until you hear a beep.

The set values are saved for the set memory level and the set dentist level.

4.7.3 Using the INTRA LUX motor K 200/KL 701 and COMFORTdrive 200XD



Note

Follow the instructions for use and assembly in the instrument packaging.

The following settings can be changed:

- Speed
- Preset spray
- Cold light preselection and intensity
- Direction of motor rotation



Note

The minimum and maximum speed depends on the motor and the attached hand-piece or contra-angle handpiece.

The speed cannot be stored.



Note

The motor mode is equivalent to 2 minutes operating time and 5 minutes pause. This represents the possible maximum load of the motor (full load at maximum speed).

In practice, pulse loads lasting seconds or pause times lasting seconds or minutes are realistic given that the maximum possible motor current is not normally reached. This equates to the dentist's normal way of working.

Adjust the motor without Memospeed

The speed, spray preset and cold light are set and the values are saved in the same manner as with the turbine.

See also: 4.7.2 Adjust the turbine without Memospeed , Page 61

Setting the rotational direction of the motor



Note

Only change the rotary direction of the motor when the motor is not running.

- ▶ Remove the motor from the holder.
- ▶ Press the "counter-clockwise motor" button.

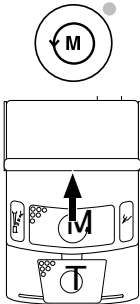

or

- ▶ Press the "Counterclockwise motor rotation" cross-switch.

The LED shines when CCW motor rotation is set.

Adjust the motor with Memospeed

- ▶ Remove the motor from the holder.
- ▶ Press the Preselect level button to select the level.

See also: 4.7.1 Select a memory level when the Memospeed is mounted, Page 60

Adjust the speed and cold light intensity

On levels 1 to 2, the speed range can be individually changed. Reducing the speed range allows finer adjustment with the foot control. The preset minimum cannot be reduced, and the preset maximum cannot be increased.



Note

The speed range cannot be preset in level E.

	K200 motor	fromKL701 motor	COMFORTdrive 200XD
Minimum	400 rpm	2,000 rpm	30,000 rpm (Display 1)
Maximum	40,000 rpm	40,000 rpm	200,000 rpm (Display 10)



- ▶ Press the "Level selection" button until you hear a beep. The display switches to the setting menu for minimum.

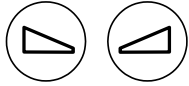
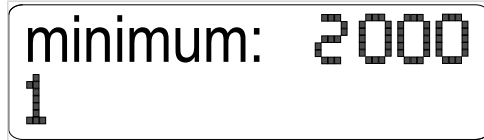

- ▶ Press the "Increase value" or "Decrease value" button until the desired value is displayed.



- ▶ Press the "Level selection" button.
The display switches to the setting menu for maximum.

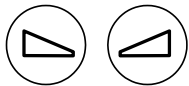
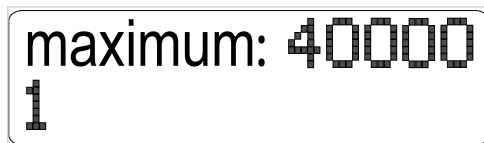

- ▶ Press the "Increase value" or "Decrease value" button until the desired value is displayed.



- ▶ Press the "Preselect level" key.
The display changes to the setting for the cold light intensity.



- ▶ Set the cold light with the "Cold light" button.
- See also:** 4.7.2 Adjust the turbine without Memospeed , Page 61
- ▶ To save the values, press the "Preselect level" button until you hear a beep.

Setting the rotational direction of the motor

The motor rotary direction is selected in the same way as without the Memospeed.

See also: 4.7.3 Setting the rotational direction of the motor, Page 65

Setting the cooling level

The cooling is adjusted in the same manner as with the turbine.

See also: 4.7.2 Adjust the turbine without Memospeed , Page 61

4.7.4 Operating the PIEZOlux



Danger of injury when the torque wrench is laid down
from the sharp-edged instrument insert

- ▶ Leave the torque wrench on the handpiece when it is not being used.



Danger of injury from the insert breaking off
from a defective instrument insert

CAUTION

- ▶ Before each use, check the condition of the instrument insert and apply approximately 10 N (about 1 kg).

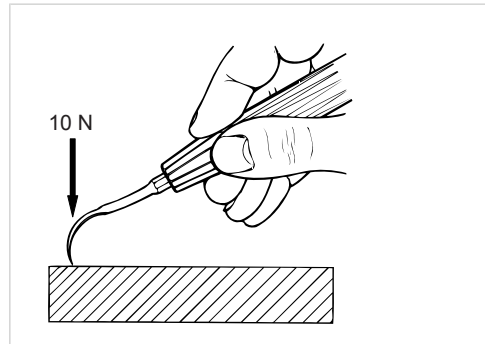

Note

The torque wrench is subject to natural wear and should be changed when it longer works properly. (Mat. no. 1.000.4887)

The following settings can be changed

- Water emission
- Intensity
- Cold light

Attaching the instrument insert

- ▶ Screw in the instrument insert into the handpiece using the torque wrench that is provided as an accessory.
- ▶ Tighten the torque wrench until it slips. The maximum torque is reached.

Adjust the water emission

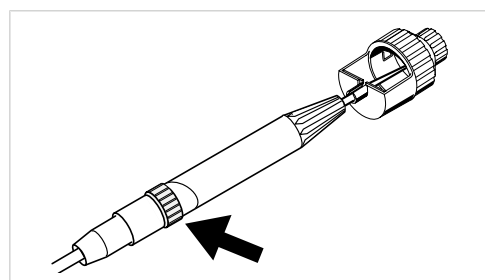

- ▶ Turn the ring on the handpiece.

Adjust the PIEZOlux without Memospeed

The cold light is set and saved as with the turbine.

The intensity is adjusted in the same manner as setting the speed of the turbine.

See also: 4.7.2 Adjust the turbine without Memospeed , Page 61

Adjust the PIEZOlux with Memospeed

The cold light is set and saved as with the turbine.

See also: 4.7.2 Adjust the turbine with Memospeed , Page 62

Set intensity



Note

The intensity can be set in level E only with the foot pedal.

The intensity is set in steps of 0.25; the minimum intensity is 1, and the maximum is 10.

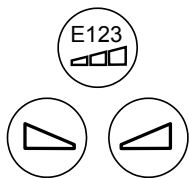

- ▶ Press the "Level selection" button until you hear a beep.
- ▶ Press the "Increase value" or "Decrease value" button until the desired value is set.

Changing the high-pressure lamp



Injury hazard from hot valve body

Burns from contact

- ▶ Switch main device switch off.
 - ▶ Let the lamp cool down after long use.
-
- ▶ Turn off the device.

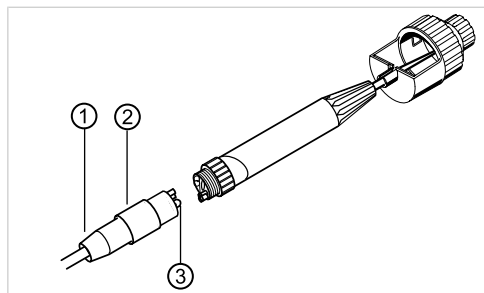

- ▶ Screw the hose sleeve ① off the handpiece, and pull the handpiece off the hose coupling ②.
- ▶ Pull the high-pressure lamp ③ out of the socket.
- ▶ Insert the new high pressure lamp (**Mat. no. 1.002.2928**) into the socket, and make sure that the contacts are correctly positioned.
- ▶ Connect the handpiece to the hose coupling, and screw it on with the hose sleeve.

4.7.5 Using the triple and multifunction handpiece

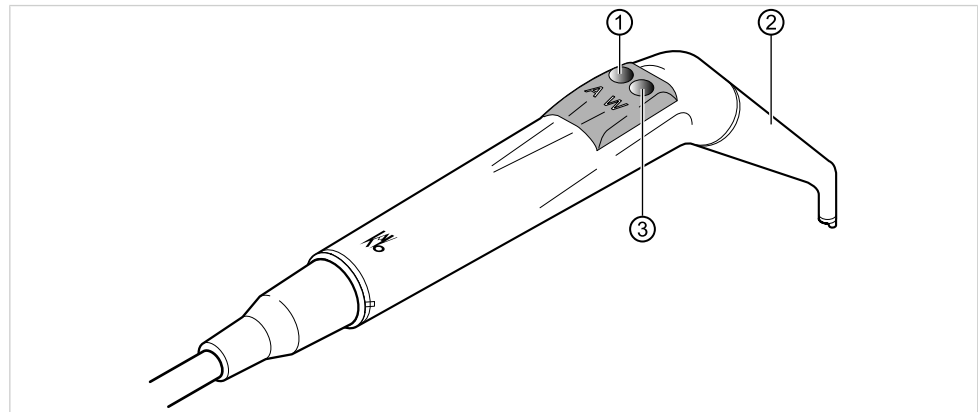

① "Air" button
② Cannula

③ "Water" button



Danger of injury from cannulas that are worn or not locked into place

Swallowing the cannula

- ▶ Before each treatment, ensure that the cannula is locked into place and firmly seated.
- ▶ Only use original KaVo cannulas.



Injury hazard from touching the cheek with the handpiece

Irritation of the mucosa

- ▶ Turn the handpiece cannula so that the mucosa is not touched.



Note

The cannula can rotate 360 degrees.

The max. "on" time is 5 minutes with a resting time of 3 minutes.

- ▶ Remove the handpiece from the holder.
 - ▶ Check the passage of the media through the cannula before using it on the patient.
 - ▶ Press the "Air" button ①; the exiting air flow can be gradually increased or decreased by applying more or less pressure on the "Air" button.
- or
- ▶ Press the "Water" button ③; the exiting water jet can be gradually increased or decreased by applying more or less pressure on the "Water" button.
- or
- ▶ Simultaneously press the "Air" button ① and "Water" button ③; the exiting spray can be gradually increased or decreased by applying more or less pressure on the button.
 - ▶ Place the handpiece in the holder after use.

Set the functions on the multifunctional handpiece

The following settings can be changed:

- Preset spray

- Cold light
- Heating

The settings can be made separately on the Comfort dentist unit and assistant unit. The settings can only be made on the dentist unit for the standard assistant unit.



Note

Afterglow time and cold light intensity are constant.

Make the settings on the dentist unit

- ▶ Remove the turbine from the holder. The holder switch is actuated.
- ▶ Press the "Preselected spray" button.

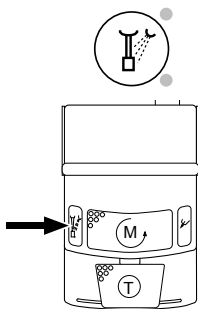

or

- ▶ "Preselected spray" footswitch. LED shines: Heating and cold light for the dentist unit handpiece have been preselected.



- ▶ To save the setting, press the "LP/AP" button until you hear a beep.

Enter settings on the Comfort assistant unit

- ▶ Remove the turbine from the holder.
- ▶ Briefly press the "Air" ① or "Water" ③ button.
- ▶ Press the "Preselected spray" button.

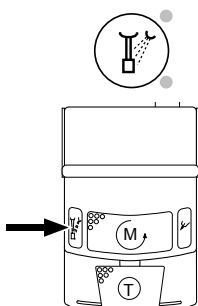

or

- ▶ "Preselected spray" footswitch. LED shines: The heating for the assistant unit handpiece is preset.



- ▶ Press the "Cold light" button. LED shines: The cold light for the assistant unit handpiece is preset.



- ▶ To save the setting, press the "LP/AP" button until you hear a beep.

Changing the high-pressure lamp



Injury hazard from hot valve body

Burns from contact

- ▶ Switch main device switch off.
- ▶ Let the lamp cool down after long use.

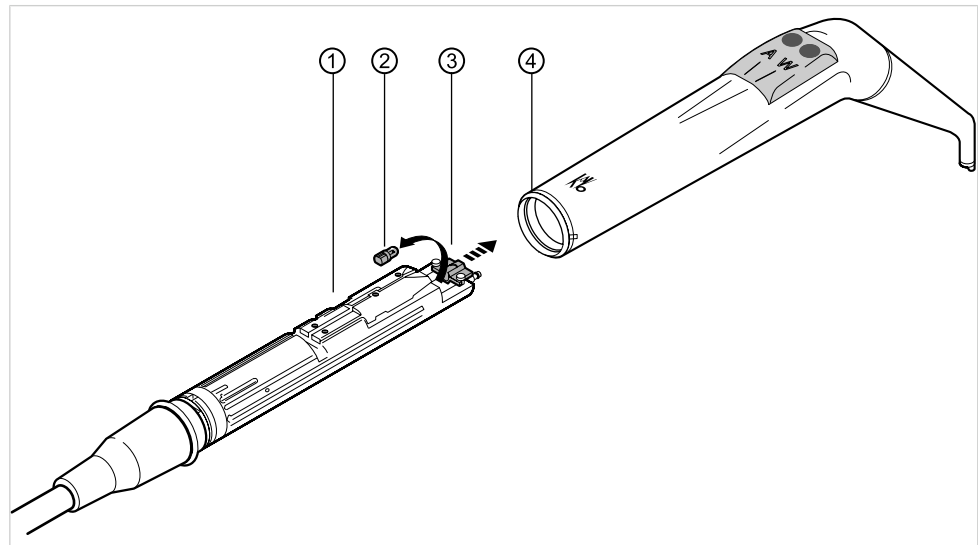

- ▶ Remove the grip sleeve ④ and the cannula from the base unit ①.
- ▶ Push the holder ③ forward, and pull the defective high-pressure bulb ② out of the socket.
- ▶ Insert the new high-pressure lamp (**Mat. no. 1.002.2928**).
Check the position of the contacts.
- ▶ Push the grip sleeve and cannula on together until they audibly lock into place.

4.7.6 Adjusting the suction



Unintentionally activating the saliva ejector or spray fog suction

Injury in the area of the mouth

- ▶ When using the vacuum stop to interrupt suction, do not leave the saliva ejector or spray fog suction in the patient's mouth.

Adjusting the suction strength

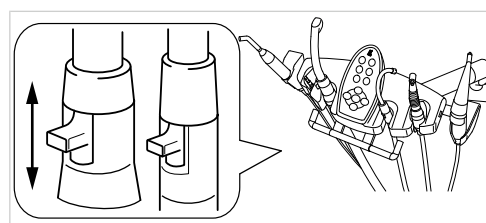

- ▶ To set the suction or block it, move the slides that are integrated in the conical pieces of the saliva ejector and spray fog suction.

Start/stop the suction on the standard assistant unit



Note

The standard assistant unit does not have a holder switch. The suction therefore has to be turned on manually.



- ▶ To turn the suction on and off, move the joystick up or down.

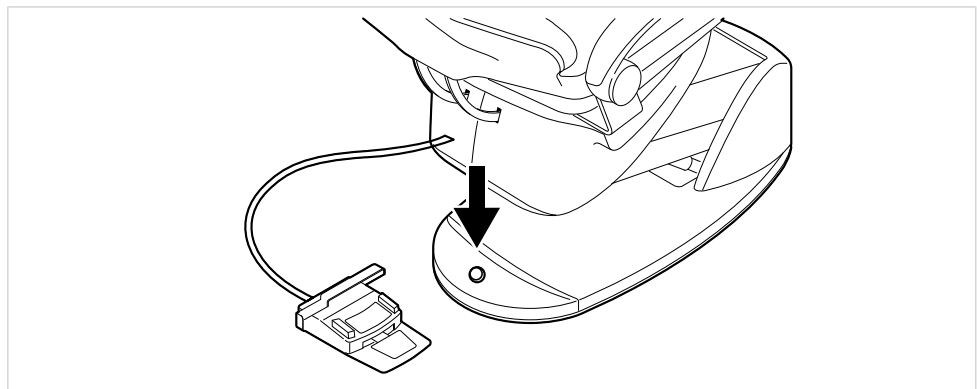

- ▶ To interrupt the suction, press the "vacuum stop" button.
- ▶ To restart the suction, press the "vacuum stop" button again.



Note

The function of the "Vacuum stop" button can be adjusted in service mode (group 9, index 11). The suction can be stopped as long as the "Vacuum stop" button is held, or the suction can be turned on or off by pressing the "Vacuum stop" button ("Vacuum stop and go").

Start/stop the suction on the Comfort assistant unit



Unintentionally activating the saliva ejector or spray fog suction

Injury in the area of the mouth

- ▶ When using the vacuum stop to interrupt suction, do not leave the saliva ejector or spray fog suction in the patient's mouth.

- ▶ Remove the saliva ejector or spray mist suction device from the holder. The suction automatically turns on.
- ▶ To interrupt the suction, press the "vacuum stop" button.
- ▶ To restart the suction, press the "vacuum stop" button again.



Note

The function of the "Vacuum stop" button can be adjusted in service mode (group 9, index 11). The suction can be stopped as long as the "Vacuum stop" button is

held, or the suction can be turned on or off by pressing the "Vacuum stop" button ("Vacuum stop and go").

5 Preparation methods DIN EN ISO 17664



Note

The preparation methods can be found in the care instructions.

6 Accessories and kits

6.1 Unit base



Note

When connecting the x-ray device In eXam be sure to observe the associated assembly instructions.

Designation	Description
Water block with integrated water disinfection system	With a DVGW permit and electronic monitoring of the disinfection container.
Water block, compact	Without DVGW permit With water filter and shutoff valve.
Water bottle with compact water block	With DVGW permit For a water supply independent from the public water supply.
Steel support base	For installing on the left or right
In eXam x-ray device	For installing on the light mounting pole. With the In eXam, the Primus 1058 can be installed using a kit (Mat. no. 1.001.0140).

6.2 Patient chair

Designation	Description
Arm rest	The armrest can be swung up to make it easier for the patient to get in and out

6.3 Patient unit with device body and assistant unit

Designation	Description
External equipment connections	To connect or supply third-party devices such as an airflow through the quick couplings.
Dürr amalgam separator Metasys Compact Dynamic	Permitted amalgam separation systems with a separation > 95%.
Metasys Compact Dynamic ECO	Dynamic separation system with a solids collector.
Dürr automatic separator	Separation using a solids separator.
Solids collector	Wastewater solids collector for wet suctioning.
External suction	Wastewater and wet suction air are drawn from a central location.
Water jet pump	For the saliva suction unit.
Monitor holder	A swingable surface for a monitor directly on the treatment unit.
KAVOSUN 1415 C / KAVOLUX 1410	Can be equipped with a treatment light if desired that can be adapted to the device.
Satelec Mini LED	LED polymerisation light
Triple-function handpiece	Multi-function syringe cold without light.
Multifunctional handpiece	Multifunctional syringe hot/cold with light.
Tray holder	For the small instrument tray.
Hot water boiler	For tumbler filling.
Low-pressure regulator	Regulator for suction air when the suction vacuum is too high.

6.4 Dentist unit

Designation	Description
Multiflex LUX hose	For connecting the turbine and SONICflex.
LUX motor hose and IN-TRA K or INTRA KLMotor electronics	for connecting the INTRA LUX motor K 200 and KL motor 701
Triple-function handpiece	Also obtainable in the standing version
PIEZOlux	Removes calculus.
X-ray viewer	The x-ray viewer 5 x 5 cm can be mounted either on the left or right side of the 1058 TM dentist unit. (With the 1058 S, only in the middle.)
Memospeed	LCD controls for the time, timer, and instrument-specific settings. Indication-related speed memory for the turbine, motor and PIEZOLUX on three programmable levels for two dentists.
Sprayer heater for instruments	For heating the spray.
Tray holder for a standard tray/US tray	For two standard trays. Can be optionally mounted on the left or right.

7 Troubleshooting



Note

In case of malfunctions, consult the separate instructions for the use and care of the individual instruments (such as the turbine, motor, camera, Satelec Mini LED, etc.).

Malfunction	Cause	Remedy
Nothing works.	Main switch is off.	▶ Turn on main switch.
	The main fuse has tripped.	▶ Unplug the unit from the mains. ▶ Check the main fuse, and change it as necessary. The main fuse is next to the main switch. ▶ Use a screwdriver to open the bayonet lock, and change microfuse T 6.3 H (Mat. no. 0.223.2783). ▶ Then close the bayonet lock with the screwdriver.
No cold light in the instruments.	Cold light not preselected.	▶ Preselect cold light.
	The high-pressure lamp in the instrument is defective.	▶ Replace the high-pressure lamp. (See the operating instructions for the instrument).
The heating function of the MF syringe doesn't work	Spring heating not preselected.	▶ Preselect spray water.
The cold light of the MF syringe doesn't work.	Cold light not preselected.	Requirement The heating function is preselected. ▶ Preselect cold light.
	High pressure lamp faulty.	▶ Replace the high-pressure lamp.
No spray in the instruments.	No spray preselected.	▶ Preselect spray.
	Close the ring for controlling the spray on the instruments.	▶ Open the ring for controlling the spray on the instruments.
	The main water valve in the office is closed.	▶ Open main valve.
	The compressor is not turned on.	▶ Turn on the compressor.
Spray at the instruments is insufficient.	The spray nozzles are dirty/clogged.	▶ Clean the spray nozzles according to the accompanying instrument operating instructions.
Turbine making loud running noises.	Turbine wheel faulty.	▶ Replace turbine wheels. Follow the operating instructions for the turbine.
Leaks in instruments.	O-rings damaged at multiflex or motor coupling.	▶ Replace O-rings.
Water in return air filter.	O-rings damaged at multiflex coupling.	▶ Replace all O-rings in the multiflex coupling.
Suction hoses not drawing.	Slides on the bodies are closed.	▶ Open slide.
	Sieves in suction connector blocked.	▶ Exchange the sieve.
	Foot switch for vacu-stop has been pressed.	▶ Release the foot switch.
	Suction machine not running.	▶ Turn on the suction machine. ▶ Check the suction machine fuse.

7 Troubleshooting

Malfunction	Cause	Remedy
	The amalgam separator does not work correctly.	▶ See the operating instructions for the amalgam separators.
The buzzer emits a continuous signal, and the "Service" LED (yellow) flashes.	Warning about the amalgam separator.	▶ See the operating instructions for the amalgam separators.
The buzzer sounds every 10 seconds.	The Oxygen container is empty.	▶ Fill the Oxygen container. (See care instructions.)
The buzzer sounds 10 times.	The Oxygen container is too full.	▶ Stop filling the Oxygen container.
A melody sounds.	The amalgam separator CAS1 is 95% full.	▶ Exchange the amalgam container.
	The CAS1 amalgam separator is defective.	See also: Instructions for use for the CAS 1 or ▶ Call a Service technician.
The Satelec Mini LED does not work.	See also: Instructions for use for the Satelec Mini LED	See also: Instructions for use for the Satelec Mini LED
The patient chair does not move.	The safety shutoff is activated. (The LED on the control panel flashes.)	▶ Check the safety shutoff and eliminate the reason for the shutoff.
The patient chair does not move, or only moves upward slightly.	The spittoon is swung toward the patient chair (the safety shutoff is activated).	▶ Swing the spittoon bowl into resting position.
The "Device on" LED (green) flashes.	Internal error.	▶ Call a technician.
The "Service" LED (yellow) flashes.	Malfunction in the amalgam separator.	▶ Call a technician.
	Emergency shut off of the bowl valve (only when external suction is installed)	▶ Call a technician.
The "Service" LED (yellow) shines.	There is no error; when the LED shines continuously, and it only indicates that Dentist level 2 is selected.	▶ To select Dentist level 1, press the foot pedal and hold it down, and press the stirrup switch. See also: 4.6.1 Select memory level Dentist 1 or Dentist 2, Page 56
The LEDs on buttons AP0, AP1, AP2 and SP shine for three seconds after the patient chair has been actuated.	The position pickup is defective or is incorrectly addressed.	▶ Call a technician.
The LED on the LP/AP button flickers.	The data connection to the multifunctional foot control is faulty.	▶ Call a technician.
The LED on the SP button flickers.	The data connection to the position pickup is faulty.	▶ Call a technician.
The LED on the AP0 button flickers.	The data connection to the dentist unit is faulty.	▶ Call a technician.

8 Do safety checks



Note

The instructions in the "Safety" chapter must be followed.

According to VDE 0751-1

- Every two years according to IIa
- Device type II a (without HF)
- Device tightly connected
- Type BF comment 2
- Measurement of EUL/EPL

KaVo offers a medical device book for keeping an inventory and recording essential master data on the medical device. The medical device book is only required in Germany and is therefore only in German (**Mat. no. 0.789.0480**).

The following measurements must be documented, for example in the medical device book.

- Check the ratings of fuses that are accessible from outside.
- Visually inspect the medical device and accessories
- Protective conductor tests according to VDE 0751-1
- Leakage current measurements according to VDE 0751-1
- Medical device function test with reference to accompanying documentation



Note

The main switch of the device system must be turned on during measurement.

Examples of measuring tools are:

KaVo test cable (**Mat. no. 0.411.8811**)

EPA measuring line ((10019904))

8.1 Measure the protective conductor resistance

Threshold: $< 0.3 \Omega$

The protective conductor resistance must be measured at the following parts of the device:

- Unit base
- Patient chair (standard or COMPACTchair)



Note

Take into account additional measuring points for auxiliary equipment: Such as an outside equipment connection, treatment lights, multimedia system.

8 Do safety checks | 8.1 Measure the protective conductor resistance

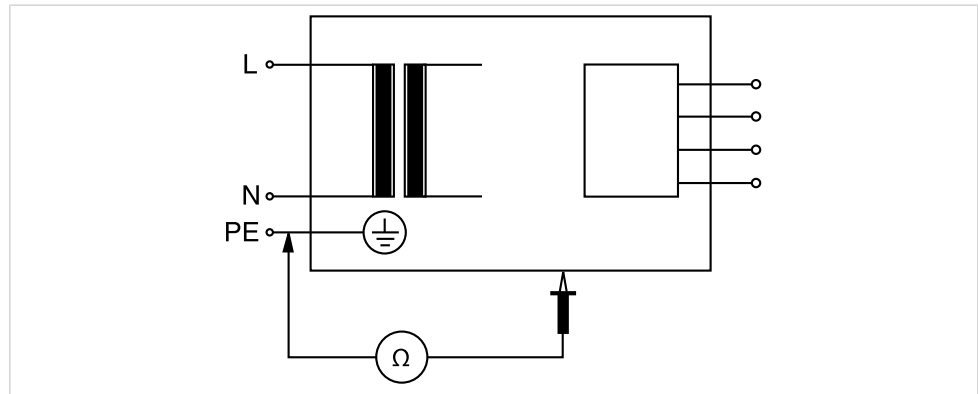

- ▶ Raise the patient chair.
- ▶ Scan the following positions with the test tip.

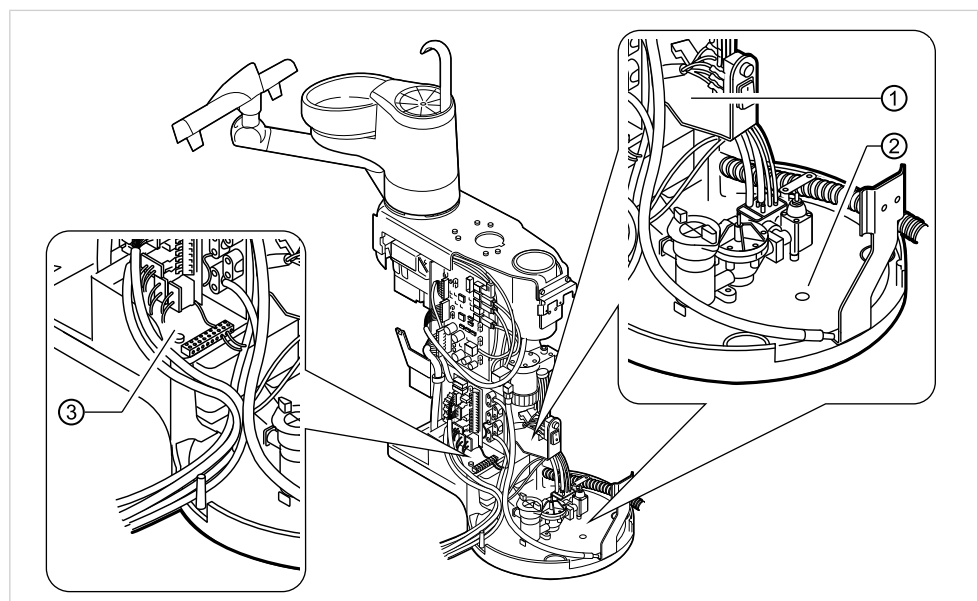

Measuring points on the device base

- ① Surroundings of the equipotential bonding terminal
- ② Main switch holding plate
- ③ Stand cover basic plate

8 Do safety checks | 8.1 Measure the protective conductor resistance

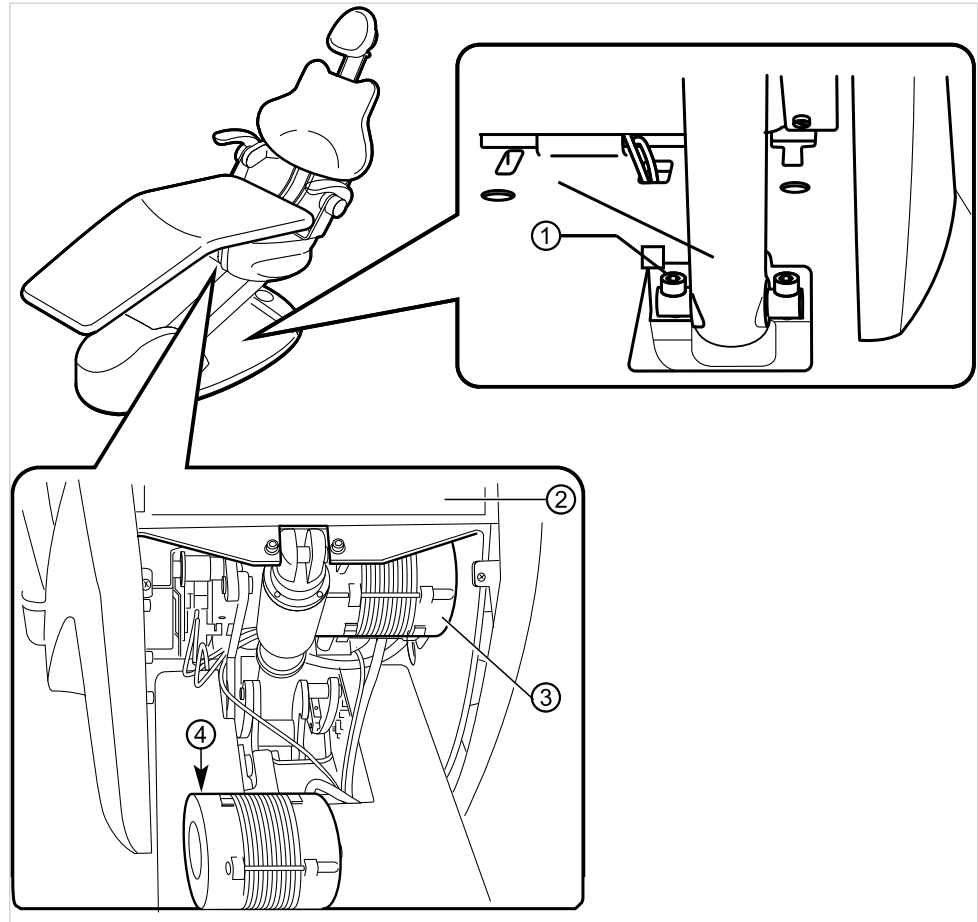

Standard patient chair measuring points

- ① Patient chair base plate
- ② Support plate for the top part of the chair
- ③ Backrest spindle motor
- ④ Lift spindle motor
- ⑤ Chair power supply (without picture)

8 Do safety checks | 8.1 Measure the protective conductor resistance

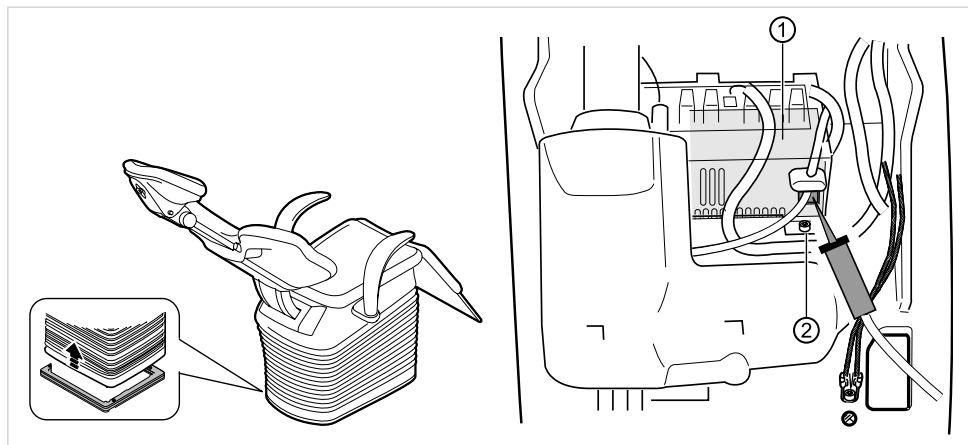

COMPACTchair measuring points

① Chair power supply

② Chair base plate

8.2 Measure equivalent unit leakage current

Threshold: < 10 mA

The equivalent unit leakage current (EUL) can be measured using an EPA measuring line (**Mat. no. 1.001.9904**) or at the falling measuring points on the patient chair:

- Fuses F5, F6 and F10 and X



Note

Take into account additional measuring points for auxiliary equipment: Such as an outside equipment connection, treatment lights, multimedia system.

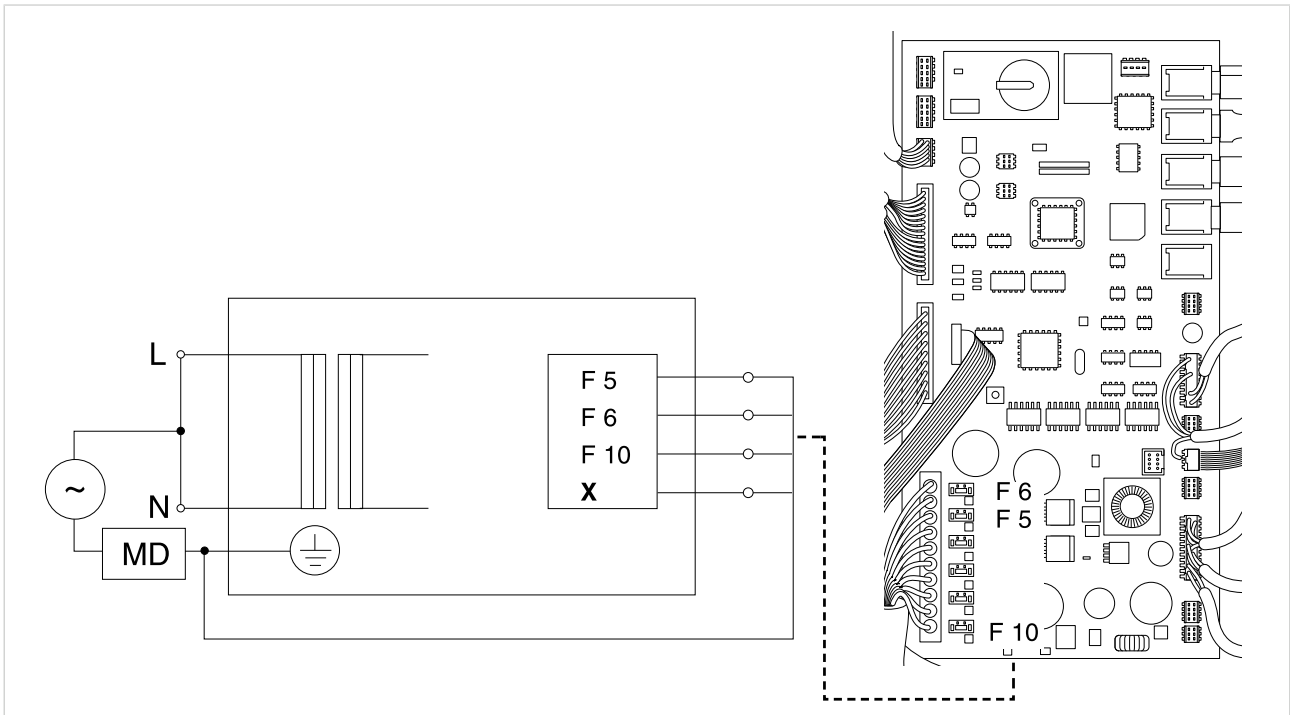

8 Do safety checks | 8.2 Measure equivalent unit leakage current

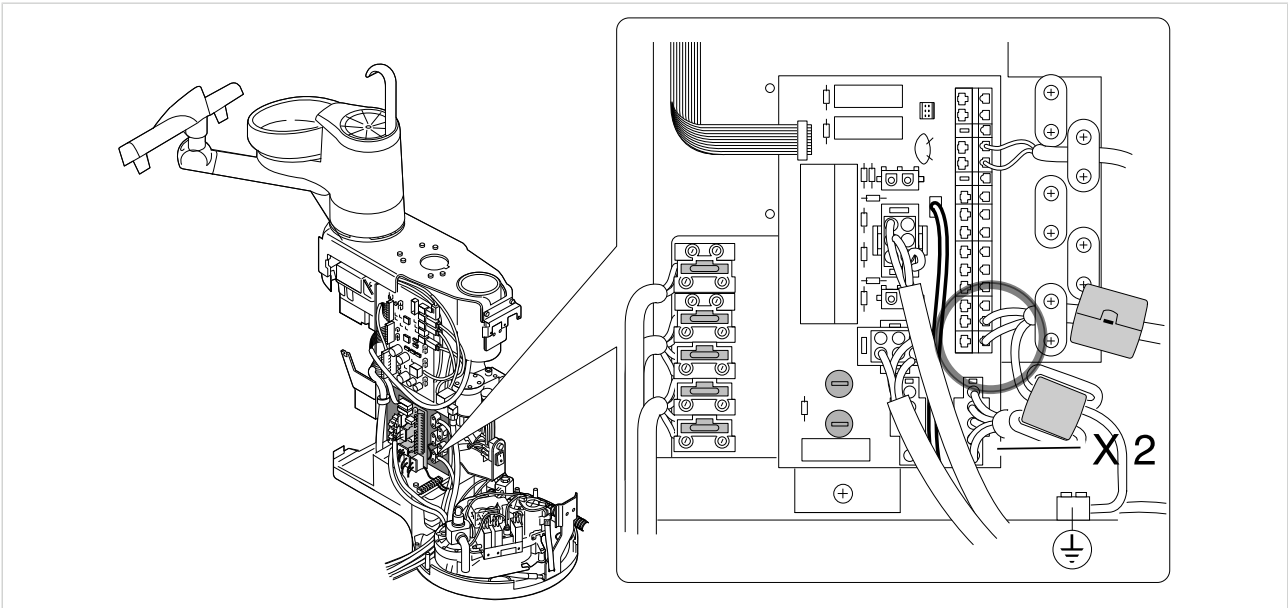

- ▶ Disconnect L + N at the device side from the mains, or connect measuring line **Mat. no. 0.411.8811** to X 2.
- ▶ Check the EUL at the measuring points or with an EPA measuring line **Mat. no. 1.001.9904**.

8.3 Measure equivalent patient leakage current

Threshold: < 5 mA

The equivalent patient leakage current (EPL) can be measured using an EPA measuring line (**Mat. no. 1.001.9904**) or at the falling measuring points on the patient chair:

- Fuses F5, F6 and F10 and X



Note

Take into account additional measuring points for auxiliary equipment: Such as an outside equipment connection, treatment lights, multimedia system.

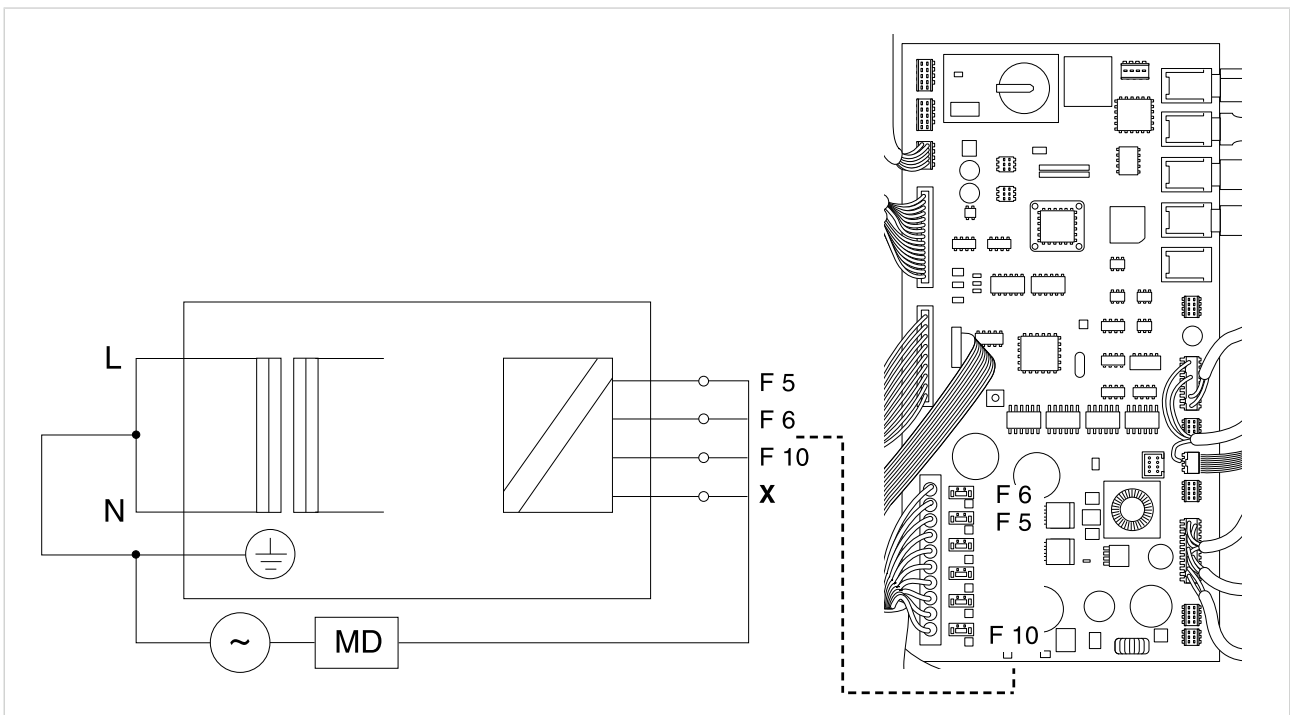

- ▶ Disconnect L + N device-side from the mains.
- ▶ Check the EPA at the measuring points or with an EPA measuring line **Mat. no. 1.001.9904**.

9 Data on electromagnetic compatibility according to EN60601-1-2

9.1 Electromagnetic Transmissions

The PRIMUS 1058 treatment unit is for use in an environment like the one cited below. The customer or user of the PRIMUS 1058 should ensure that it is used in the correct environment.

Measurements of noise transmissions	Conformance	Electromagnetic environment - hints
HF transmission according to CISPR 11	Group 1	The PRIMUS 1058 uses HF energy only for its internal operation. Its HF transmission is therefore very low, and it is improbable that neighbouring electronic devices will be disturbed.
HF transmission according to CISPR 11	Class B	The PRIMUS 1058 is for use in all facilities including residential ones, and facilities that are directly connected to a public power supply that also supplies residential buildings.
Transmissions of harmonics according to IEC 61000-3-2	Class A	The PRIMUS 1058 is for use in all facilities including residential ones, and facilities that are directly connected to a public power supply that also supplies residential buildings.
Transmission of voltage fluctuations or flicker according to IEC 61000-3-3	Conforms	The PRIMUS 1058 is for use in all facilities including residential ones, and facilities that are directly connected to a public power supply that also supplies residential buildings.

9.2 Resistance to electromagnetic interference

The PRIMUS 1058 treatment unit is for use in an environment like the one cited below. The customer or user of the PRIMUS 1058 should ensure that it is used in the correct environment.

Immunity tests	IEC 60601 test level	Conformance level	Electromagnetic environment - guidelines
Electrostatic discharge (ESD) according to IEC 61000-4-2	± 6 kV contact discharge ± 8 kV atmospheric discharge	± 2/4/6 kV contact discharge ± 2/4/8 kV atmospheric discharge	Floors should be made of wood or concrete or have ceramic tiles. When the floor is covered with synthetic material, the relative humidity must be at least 30%.
Fast transient electrical disturbances/ Bursts according to IEC 61000-4-4	± 2 kV for power lines ± 1 kV for input and output lines	± 2 kV for power lines	The quality of the supply voltage should correspond to that of a typical business or hospital environment .
Surges according to IEC 61000-4-5	± 1 kV Push-pull voltage ± 2 kV common mode voltage	± 1 kV Push-pull voltage ± 2 kV common mode voltage	The quality of the supply voltage should correspond to that of a typical business or hospital environment .
Voltage interruptions, short-term interruptions and fluctuations of the supply voltage according to IEC 61000-4-11	< 5% U_T (>95% interruption) for 1/2 period 40 % U_T (60% interruption) for 5 periods 70 % U_T (30 % interruption) for 25 periods < 5% U_T (>95% interruption) for 5 s (250 periods)	< 5% U_T (>95% interruption) for 1/2 period 40 % U_T (60% interruption) for 5 periods 70 % U_T (30 % interruption) for 25 periods < 5% U_T (>95% interruption) for 5 s (250 periods)	The quality of the supply voltage should correspond to that of a typical business or hospital environment. When the user of the PRIMUS 1058 needs continued operation even when the power supply is interrupted, it is recommended to supply the PRIMUS 1058 from an uninterrupted power supply or a battery.
Magnetic field with a supply frequency (50/60 Hz) according to IEC 61000-4-8	3 A/m	3 A/m	Magnetic fields at the mains frequency should correspond to typical values in a business and hospital environment .

Note: V_t is the alternating mains voltage before the test level is used.

9 Data on electromagnetic compatibility according to EN60601-1-2 | 9.2 Resistance to electromagnetic interference

Immunity tests	IEC 60601 test level	Conformance level	Electromagnetic environment - guidelines
Conducted HF disturbances according to IEC 61000-4-6 Radiated HF disturbances according to IEC 61000-4-3	$3 V_{\text{eff}}$ 150 KHz to 80 MHz Outside ISM bands ^a $3 V/m$ 80 MHz to 2.5 GHz	$3 V_{\text{eff}}$ $3 V/m$	Portable and mobile radio devices should not be used closer to the PRIMUS 1058 including the wires, than the recommended safe distance calculated using the equation for the transmission frequency. Recommended safe distance: $d = 1.17 \sqrt{P}$ $d = 1.17 \sqrt{P}$ for 80 MHz to 800 MHz $d = 2.33 \sqrt{P}$ for 800 MHz to 2.5 GHz with P as the maximum rated power of the transmitter in Watts (W) according to the transmitter manufacturer, and d as the recommended safe distance in meters (m). ^b The field strength of stationary radio transmitters should be less than the conformance level at all frequencies in an on-site check ^c . ^d Disturbances are possible close to devices that have the following symbol. 

Comment 1: At 80 MHz and 800 MHz, the higher frequency range applies.

Comment 2: These guidelines may not be applicable in every case. The spread of electromagnetic waves is absorbed and reflected by buildings, objects and people.

^a The ISM frequency bands (for industrial, scientific and medical applications) between 150 kHz and 80 MHz are 6.765 MHz to 6.795 MHz; 13.553 MHz to 13.567 MHz; 26.957 MHz to 27.283 MHz and 40.66 MHz to 40.70 MHz.

^b The conformance levels in the ISM frequency bands between 150 kHz and 80 MHz and the frequency range of 80 MHz and 2.5 GHz are intended to reduce the probability that mobile and portable communications equipment will produce disturbances when they are unintentionally brought near the patient. For this reason, the additional factor of 10/3 is used when calculating the recommended safe distances within these frequency ranges.

^cThe field strength of stationary transmitters such as base stations of mobile telephones and land mobile radio devices, amateur radio stations, AM and FM, radio and television broadcasters cannot be theoretically predetermined. To determine the electromagnetic environment of stationary transmitters, a study of the location should be considered. When the measured field strength at the location on which the PRIMUS 1058 is used, exceeds the conformity level, the PRIMUS 1058 should be watched to ensure that it is functioning as per the correct usage. Should unusual

9 Data on electromagnetic compatibility according to EN60601-1-2 | 9.2 Resistance to electromagnetic interference

performance features be observed, additional measures may be required, such as e.g. a different alignment or another location for the PRIMUS 1058.

^d Within the frequency range of 150 kHz to 80 MHz, the field strength should be less than $3V_{\text{eff}}$ V/m.

9.3 Recommended safe distance between portable and mobile HF telecommunications equipment and the PRIMUS 1058

The PRIMUS 1058 is intended for use in an electromagnetic environment in which HF disturbances are controlled. The customer or the user of the PRIMUS 1058 can help prevent electromagnetic disturbances by maintaining the minimum distance between portable and mobile HF telecommunications devices (transmitters) and the PRIMUS 1058 depending on the output of the communication device as indicated below.

Safe distance depending on the transmission frequency:

Rated power of the transmitter in W	150 kHz to 80 MHz $d=1.17 \sqrt{P}$ m	80 MHz to 800 MHz $d=1.17 \sqrt{P}$ m	800 MHz to 2.5 GHz $d=2.33 \sqrt{P}$ m
0.01	0.1	0.1	0.2
0.1	0.4	0.4	0.7
1	1.2	1.2	2.3
10	3.7	3.7	7.4
100	11.7	11.7	23.3

For transmitters whose maximum rated power is not in the above table, the recommended safe distance d in meters (m) can be calculated using the equation for the respective gap, where P is the maximum rated power of the transmitter in Watts (W) according to the manufacturer's information.

NOTE 1: At 80 MHz and 800 MHz, the higher frequency range applies.

NOTE 2 These guidelines may not be applicable in every case. The spread of electromagnetic waves is absorbed and reflected by buildings, objects and people.



KaVo. Dental Excellence.